

Battery Management Solutions

High Performance Analog ICs



Linear Technology’s high performance battery management ICs enable long battery life and run time, while providing precision charging control, constant status monitoring and stringent battery protection. Our proprietary design techniques seamlessly manage multiple input sources while providing small solution footprints, faster charging and 100% standalone operation. Battery and circuit protection features enable improved thermal performance and high reliability operation.

Each battery chemistry has unique charging requirements. Selecting the correct battery charger increases the operational run time of the end product, ensuring that the battery is always optimally charged. This guide contains the essential technical criteria to easily identify the optimum battery charging IC for 1-cell to multiple-cell configurations, regardless of chemistry. Data sheets for our complete battery management product portfolio, including our latest product releases, are available for download at www.linear.com.

Contents/Block Diagrams

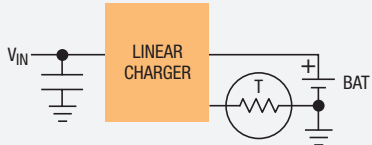
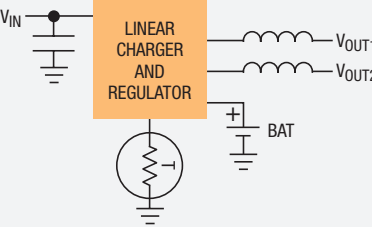
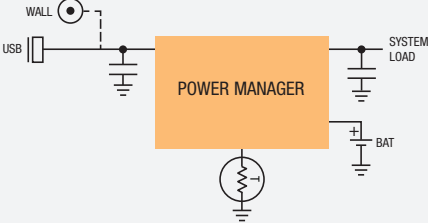
TYPE	PAGE	TOPOLOGY	BATTERY CHEMISTRY
Linear			
USB Compatible Battery Chargers	5-8		Lithium-Ion/Polymer
“X” Series–Fast Charge Depleted Batteries (No Trickle Charge).....	5, 6, 8		
4.2V Float Voltage (1- and 2-Cell) Battery Chargers	5, 6		
4.1V Float Voltage Battery Chargers	7		
Coin Cell/Low Current Battery Chargers	8		
Nickel Battery Chargers.....	9		
Linear Charger + Regulators			
Battery Chargers with Onboard Regulators or Comparators	6, 13		Lithium-Ion/Polymer
Power Managers (BAT Decoupled from V_{OUT})			
4.1V Float Voltage Power Managers	7, 10		Lithium-Ion/Polymer
Linear Power Managers.....	10		
Switch Mode Power Managers.....	10		
Controller Power Managers	19		
			LiFePO ₄

TYPE **PAGE**

Power Management Integrated Circuits (PMICs)

4.1V Float Voltage PMICs 7

Switch Mode Power Manager-Based PMICs 11

Linear Power Manager-Based PMICs 12

Battery-Fed PMICs 13

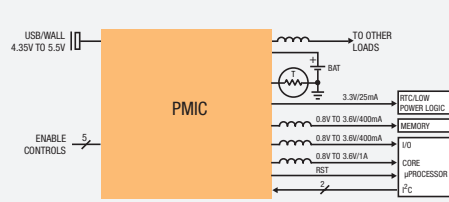

Lithium-Ion/Polymer

Switch Mode–Monolithic

Switch Mode Buck Battery Chargers 9, 14

Switch Mode Buck-Boost Battery Chargers 15

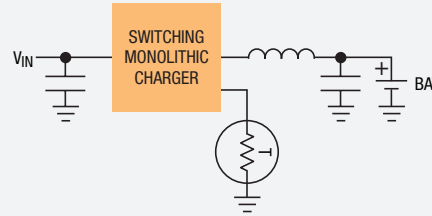

Lithium-Ion/Polymer

LiFePO₄

NiMH/NiCd

Lead-Acid

Multichemistry

Switch Mode–Controller

Switch Mode Buck Battery Charger Controllers 14

Switch Mode Buck-Boost Battery Charger Controllers 15

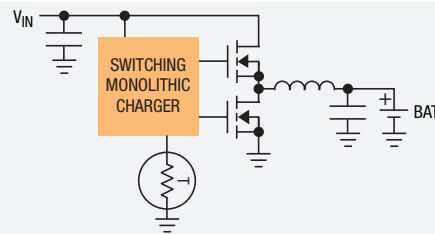

Lithium-Ion/Polymer

LiFePO₄

NiMH/NiCd

Lead-Acid

Multichemistry

Switch Mode–Smart Battery

Smart Battery Chargers 16

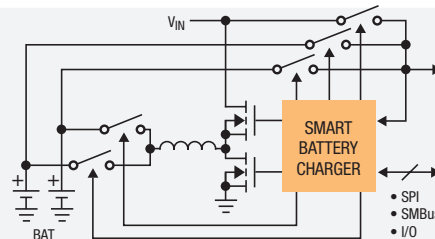

Lithium-Ion/Polymer

LiFePO₄

NiMH/NiCd

Lead-Acid

Multichemistry

Related Battery Management Products

Battery Backup System Managers 15-16

Lithium-Ion/Polymer

LiFePO₄

NiMH/NiCd

Lead-Acid

Multichemistry

Special Battery Management Function ICs 17-24

Ideal Diodes/PowerPath™ Controllers 17

Supercapacitor Chargers 18

Supercapacitor

High Side and Low Side Current Sensing 21

Battery Stack Monitors for Hybrid/Electric Vehicles and Battery Backup Systems 22-23

Battery Monitoring–Comparators & Voltage References 24

Master Selector Guides 25-29

Battery-Fed (Charger-Fed) Systems

First generation USB system applications incorporated a current-limited battery charger directly between the USB port and the battery (see Figure 1). In this battery-fed topology, the battery directly powers the system and the power available to the system from the USB can be expressed as:

$$P_{\text{SYS}} = I_{\text{USB}} \cdot V_{\text{BAT}}$$

because V_{BAT} is the only voltage available to the system load. For linear chargers, input current approximately equals charge current, so a simple current limit is sufficient. Connecting the system load directly to the battery eliminates the need for a load sharing diode. Disadvantages of this topology include low efficiency, 500mA maximum charge current from the USB, no system power when the battery voltage is low (i.e., a dead or missing battery), and loss of nearly half of the available power within the linear battery charger element as heat. Furthermore, an additional resistor and signal transistor is required to increase charge current when a wall adapter is present.

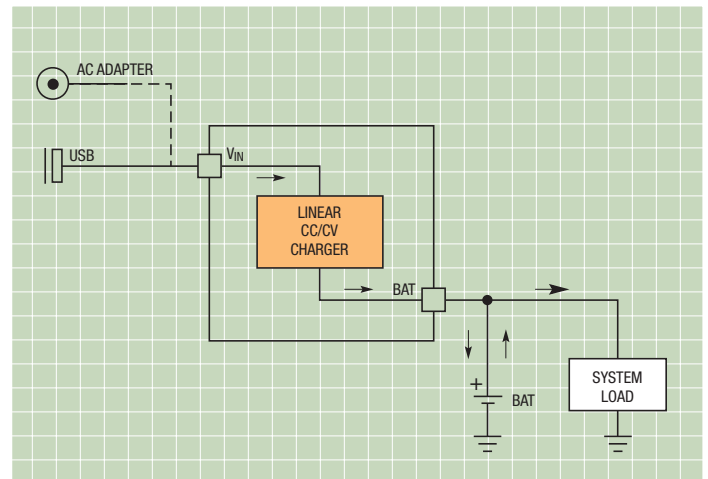

Figure 1: Simplified Battery-Fed Control Circuit

Linear PowerPath Power Managers

Second generation USB charging systems, commonly referred to as PowerPath systems, develop an intermediate voltage between the USB port and the battery (see Figure 2). In PowerPath systems, the USB port supplies current to an intermediate voltage, V_{OUT} , via a current-limited switch. V_{OUT} powers both the linear battery charger and the system load with priority going to the system load. By decoupling the battery from the system load, charging can be carried out opportunistically. PowerPath systems also offer instant-on operation because the intermediate voltage is available for system loads as soon as power is applied to the circuit—this allows the end product to operate immediately when plugged in, regardless of the battery's state of charge. In a linear PowerPath system, nearly all of

the 2.5W available from the USB port is accessible to the system load provided the system load does not exceed the input current limit. Furthermore, if the system requires more power than is available from the input, an ideal diode also supplies current to the load from the battery. Thus, a linear PowerPath system offers significant advantages over a battery-fed system. But significant power may still be lost, especially if the system load exceeds the input current limit and the battery voltage is low, resulting in a large differential between the input voltage and both the system voltage and the battery voltage. An optional external PFET can reduce the ideal diode voltage drop during heavy load conditions.

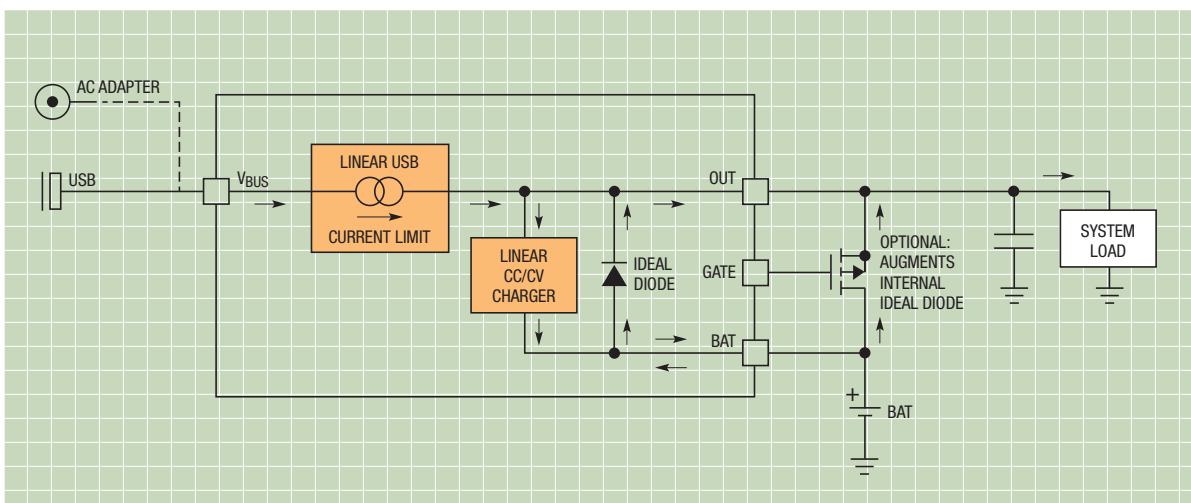

Figure 2: Simplified Linear Power Manager Circuit

Switch Mode PowerPath Power Managers

Third generation USB charging systems feature a switch mode-based topology (see Figure 3). This type of PowerPath device produces an intermediate bus voltage from a USB-compliant step-down switching regulator that regulates a small differential voltage above the battery voltage. Linear Technology refers to this as Bat-Track™ adaptive output control because the output voltage tracks the battery voltage. The differential voltage between the battery and the system is large enough to allow full charging through the linear charger, but small enough to minimize power lost in the charger, thereby increasing system efficiency and maximizing power available to the load. The switching average input current limit allows the use of nearly all of the 2.5W available from the USB port, independent of operating

conditions. By ensuring that the Bat-Track regulation loop does not allow the output voltage to drop below 3.5V (even with severely discharged batteries) this topology also provides instant-on functionality. As in linear PowerPath systems, an ideal diode allows the battery to supplement input power during heavy load transients. An optional external PFET can reduce the ideal diode voltage drop. This architecture is suitable for systems with large (>1.5Ahr) batteries and high (>2W) system power.

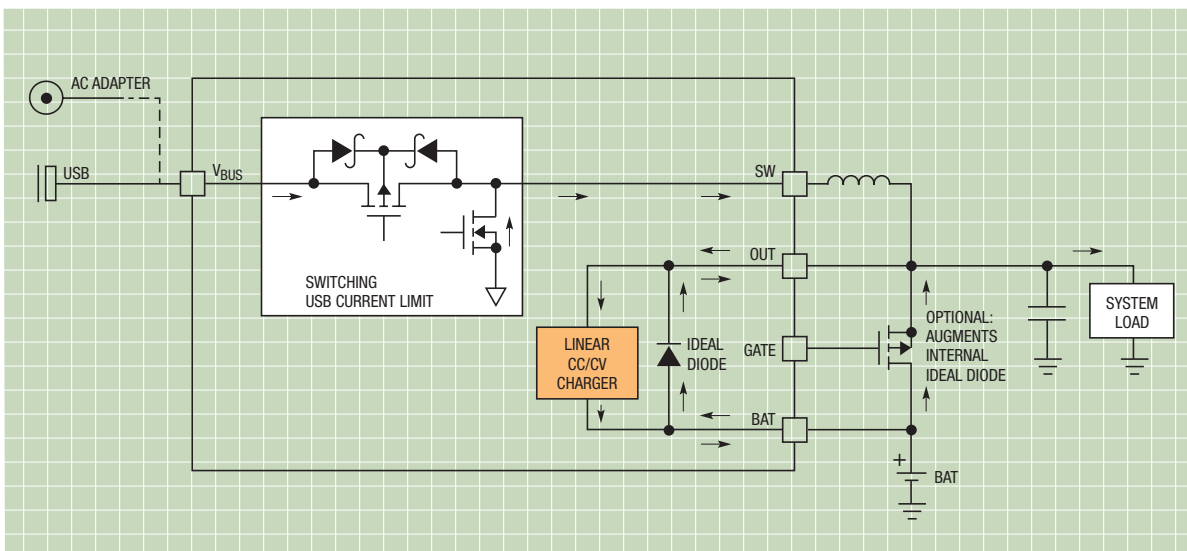

Figure 3: Simplified Switch Mode Power Manager Circuit

External High Voltage Switching Regulator Control

Several Linear Technology power manager ICs (both linear and switching) provide the ability to adaptively control the output of an external high voltage switching regulator (see Figure 4). The WALL pin detects the presence of a high voltage supply (e.g., car battery, 12V wall adapter, FireWire input) and enables Bat-Track adaptive output control via the buck regulator’s V_C pin. Similar to a switching PowerPath system, the output of the high voltage buck is regulated to a small differential voltage above the battery voltage with a minimum output voltage of approximately 3.5V. This functionality maximizes charger efficiency while still allowing instant-on operation even when the battery is deeply discharged. Compared to the

traditional approach of converting a high voltage input to 5V to power the system, this technique can reduce system power dissipation by over 50%. By choosing an LT[®]3653 as the high voltage regulator, further system improvements can be made (see Figure 5). The LT3653 accurately controls its maximum output current, which eliminates the potential for localized heating, reduces the required current rating of the power components and provides a robust solution to withstand harsh overload and short circuit conditions. In addition, the unique LT3653 architecture eliminates a power PFET and output capacitor from the application schematic.

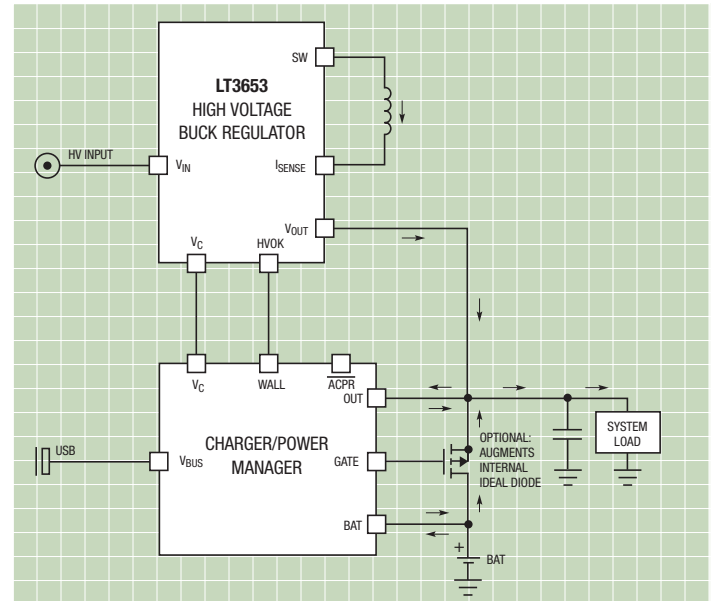
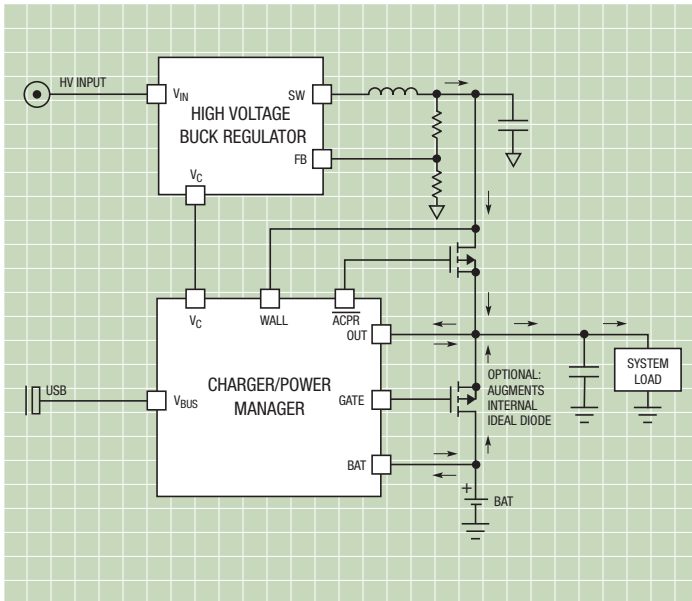

Figure 4: Simplified HV Switching Regulator Control Circuit

Figure 5: Simplified LT3653 Control Circuit

Attribute	Battery-Fed	Linear PowerPath	Switch Mode PowerPath
Table 1: Comparison of USB-Compliant Battery Charging System Topologies			
Size	Small	Moderate	Larger
Complexity	Simple	Moderate	More Complex
Solution Cost	Low	Moderate	Higher
USB Charge Current	Limited to 500mA	Limited to 500mA	500mA and Higher (~2.3W)
Autonomous Control of Input Power Sources	No	Yes	Yes
Instant-On Operation	No	Yes	Yes
System Load Efficiency ($I_{BUS} < \text{USB Limit}$)	Good (V_{BAT}/V_{BUS})	Exceptional (>90%)	Excellent (~90%)
System Load Efficiency ($I_{SYS} > \text{USB Limit}$)	Good (V_{BAT}/V_{BUS})	Good (V_{BAT}/V_{BUS})	Excellent (~90%)
Battery Charger Efficiency	Good (V_{BAT}/V_{BUS})	Good (V_{BAT}/V_{BUS})	Excellent (~90%)
Power Dissipation	High	Moderate	Low
Bat-Track Adaptive Output Control/Interface to HV Buck	No	Yes	Yes

Linear Li-Ion/Polymer Battery Chargers

We produce a comprehensive line of high performance battery chargers for any rechargeable battery chemistry, including lithium-ion, lithium-polymer, lead acid, and nickel-based. Our linear battery charger ICs are completely autonomous in operation and offer many standard features for battery safety and management, including on-chip battery preconditioning, status signaling, thermal regulation and NTC thermistor interface.

LTC[®]4095: USB Li-Ion/Polymer Battery Charger in 2mm x 2mm DFN

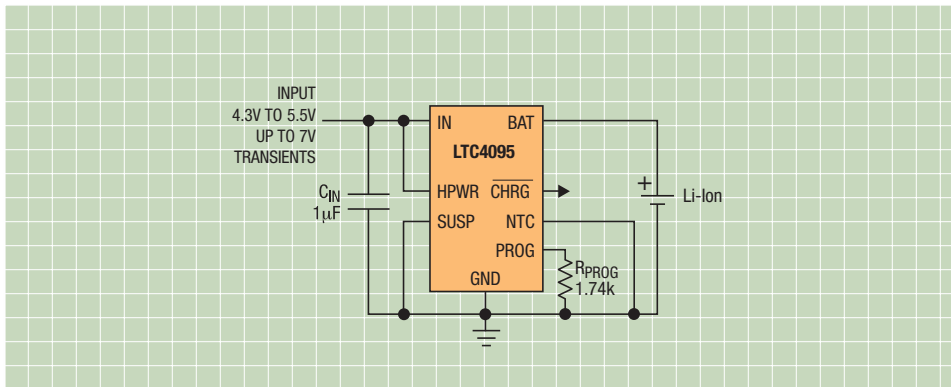

500mA Single Cell Li-Ion Charger

LTC4095:
Actual Size
Demo Circuit



LTC4078/X: Dual Input Li-Ion/Polymer Battery Charger with Overvoltage Protection

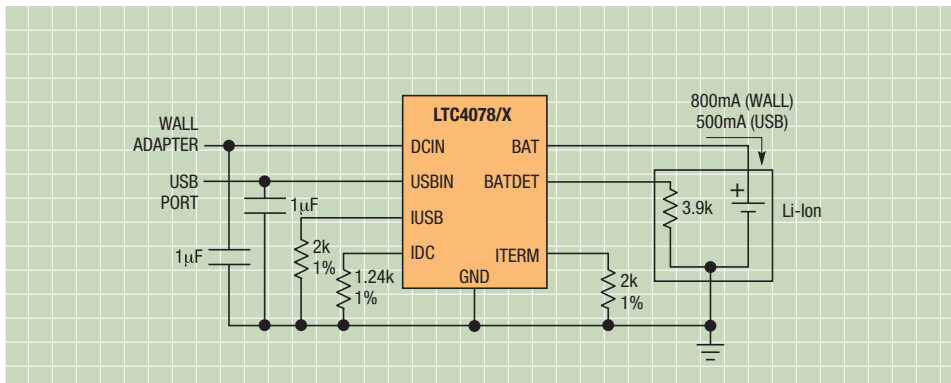

High Voltage Dual Input Battery Charger for Li-Ion Battery Pack

Part Number	Number of Battery Cells (Series)	Maximum Charge Current (A)	Input Voltage (V)	Cell Type	Integrated Power Transistor	Charge Termination (Plus Indication)	Package (mm x mm)
Linear Li-Ion/Polymer Battery Chargers							
LTC4054L	1	0.15	4.25 to 6.5	Li-Ion/Poly	✓	C/10	ThinSOT™
LTC1734L	1	0.18	4.55 to 8	Li-Ion/Poly	External	External µC	ThinSOT
LTC4065L/X	1	0.25	3.75 to 5.5	Li-Ion/Poly	✓	Timer + C/10	2x2 DFN-6
LTC4080*/X* ¶	1	0.5	3.75 to 5.5	Li-Ion/Poly	✓	Timer + C/10	3x3 DFN-10, MSOP-10E
LTC4081*	1	0.5	3.75 to 5.5	Li-Ion/Poly	✓	Timer + C/10	3x3 DFN-10
LTC4056*	1	0.7	4.5 to 6.5	Li-Ion/Poly	External	Timer	ThinSOT
LTC1734	1	0.7	4.55 to 8	Li-Ion/Poly	External	External µC	ThinSOT
LTC4065*	1	0.75	3.75 to 5.5	Li-Ion/Poly	✓	Timer + C/10	2x2 DFN-6
LTC4065-4.4*	1	0.75	3.75 to 5.5	Li-Ion/Poly	✓	Timer + C/10	2x2 DFN-6
LTC4065A*	1	0.75	3.75 to 5.5	Li-Ion/Poly	✓	Timer + C/10	2x2 DFN-6
LTC4069*	1	0.75	3.75 to 5.5	Li-Ion/Poly	✓	Timer + C/10	2x2 DFN-6
LTC4069-4.4*	1	0.75	3.75 to 5.5	Li-Ion/Poly	✓	Timer + C/10	2x2 DFN-6
LTC4054*/X* ¶	1	0.8	4.25 to 6.5	Li-Ion/Poly	✓	C/10	ThinSOT
LTC4057*	1	0.8	4.25 to 6.5	Li-Ion/Poly	✓	External µC	ThinSOT
LTC4059*	1	0.9	3.75 to 8	Li-Ion/Poly, Ni †	✓	External µC	2x2 DFN-6
LTC4059A*	1	0.9	3.75 to 8	Li-Ion/Poly, Ni †	✓	External µC	2x2 DFN-6
LTC4058*/X* ¶	1	0.95	4.25 to 6.5	Li-Ion/Poly	✓	C/10	3x3 DFN-8
LTC4068*/X* ¶	1	0.95	4.25 to 6.5	Li-Ion/Poly	✓	C/x	3x3 DFN-8
LTC4075*/X* ¶	1	0.95	4.3 to 8	Li-Ion/Poly	✓	C/x	3x3 DFN-10
LTC4075HVX* ¶	1	0.95	4.3 to 6, 22 max	Li-Ion/Poly	✓	C/x	3x3 DFN-10
LTC4078*/X* ¶	1	0.95	4.3 to 6, 22 max	Li-Ion/Poly	✓	C/x	3x3 DFN-10
LTC4076*	1	0.95	4.3 to 8	Li-Ion/Poly	✓	C/x	3x3 DFN-10
LTC4077*	1	0.95	4.3 to 8	Li-Ion/Poly	✓	C/10	3x3 DFN-10
LTC3550-1*	1	0.95	4.3 to 8	Li-Ion/Poly	✓	C/x	3x5 DFN-16
LTC3550*	1	0.95	4.3 to 8	Li-Ion/Poly	✓	C/x	3x5 DFN-16
LTC3552-1*	1	0.95	4.25 to 8	Li-Ion/Poly	✓	C/x	3x5 DFN-16
LTC3552*	1	0.95	4.25 to 8	Li-Ion/Poly	✓	C/x	3x5 DFN-16
LTC4095*	1	0.95	4.3 to 5.5	Li-Ion/Poly	✓	Timer + C/10	2x2 DFN-8
LTC4064*	1	1.0	4.25 to 6.5	Li-Ion/Poly	✓	Timer + C/10	MSOP-10E
LTC4061*	1	1.0	4.5 to 8	Li-Ion/Poly	✓	Timer + C/x	3x3 DFN-10
LTC4061-4.4*	1	1.0	4.5 to 8	Li-Ion/Poly	✓	Timer + C/x	3x3 DFN-10
LTC4062* †	1	1.0	4.3 to 8	Li-Ion/Poly	✓	Timer + C/x	3x3 DFN-10
LTC4063* §	1	1.0	4.3 to 8	Li-Ion/Poly	✓	Timer + C/x	3x3 DFN-10
LTC4096*/X* ¶	1	1.2	4.25 to 5.5	Li-Ion/Poly	✓	C/x	3x3 DFN-10
LTC4097*	1	1.2	4.25 to 5.5	Li-Ion/Poly	✓	C/x	2x3 DFN-12
LTC4053*	1	1.25	4.25 to 6.5	Li-Ion/Poly	✓	Timer + C/10	3x3 DFN-10, MSOP-10E
LTC4052 #	1	1.3	4.5 to 10	Li-Ion/Poly	✓	Timer + C/10	MSOP-8E
LTC1733	1	1.5	4.5 to 6.5	Li-Ion/Poly	✓	Timer + C/10	MSOP-10E
LTC1731	1, 2	1.5	4.5 to 12	Li-Ion/Poly	External	Timer + C/10	MSOP-8, SO-8
LTC1732	1, 2	1.5	4.5 to 12	Li-Ion/Poly, Ni †	External	Timer + C/10	MSOP-10

* USB 2.0 Compatible, † Onboard Comparator, ‡ Constant-Current Mode (Voltage Mode Disabled), § Onboard LDO, ¶ "X" (No Trickle Charge) Versions Useful when the System Load Exceeds the Trickle Charge Current at Very Low Battery Voltages

Pulse Charger

4.1V/Cell Battery Float Voltage

Our 4.1V per cell float voltage chargers improve battery life and high temperature safety margin by accurately charging the battery to a level slightly below full charge.

Part Number	Number of Battery Cells (Series)	Maximum Charge Current (A)	Input Voltage (V)	Battery Charger Type	USB 2.0 Compatible	Interface to High Voltage Buck	PowerPath Control	Integrated DC/DC Converters	Package (mm x mm)
Linear and Switch Mode Battery Chargers, Power Managers, Smart Battery Chargers and PMICs—4.1V/Cell Float Voltage									
LTC4070	1	0.05 [†]	Unlimited	Shunt	–	–	–	–	2x3 DFN-8, MSOP-8E
LTC4071	1	0.05	Unlimited	Shunt	–	–	–	–	2x3 DFN-8, MSOP-8E
LTC3455-1	1	0.5	2.7 to 5.5	Linear	✓	–	✓	2 Bucks	4x4 QFN-24
LTC1734-4.1	1	0.7	4.55 to 8	Linear	✓	–	–	–	ThinSOT
LTC3559-1	1	0.95	4.3 to 5.5	Linear	✓	–	–	2 Bucks	3x3 QFN-16
LTC4055-1	1	1	4.3 to 5.5	Linear	✓	–	✓	–	4x4 QFN-16
LTC4064 (4.0V)	1	1	4.25 to 6.5	Linear	✓	–	–	–	MSOP-10E
LTC4089-1	1	1.2	6 to 36	Linear	✓	–	✓	–	3x6 DFN-22
LTC1733 [‡]	1	1.5	4.5 to 6.5	Linear	✓	–	–	–	MSOP-10E
LTC4066-1	1	1.5	4.3 to 5.5	Linear	✓	–	✓	–	4x4 QFN-24, 4x4 QFN-24
LTC4085-1	1	1.5	4.35 to 5.5	Linear	✓	–	✓	–	3x4 DFN-14
LTC3557-1	1	1.5	4.35 to 5.5	Linear	✓	✓	✓	3 Bucks, 1 LDO	4x4 QFN-28
LTC3577-1/-4	1	1.5	4.35 to 5.5	Linear	✓	✓	✓	3 Bucks, 2 LDOs, 10-LED Boost	4x7 QFN-44
LTC3576-1	1	1.5	4.35 to 5.5	Bat-Track Linear	✓	✓	✓	3 Bucks, 1 LDO	4x6 QFN-38
LTC3555-3	1	1.5	4.35 to 5.5	Bat-Track Linear	✓	–	✓	3 Bucks, 1 LDO	4x5 QFN-28
LTC3586-1	1	1.5	4.35 to 5.5	Bat-Track Linear	✓	–	✓	1 Boost, 1 Buck-Boost, 2 Bucks, 1 LDO	4x6 QFN-38
LTC4098-1	1	1.5	4.35 to 5.5	Bat-Track Linear	✓	✓	✓	–	3x4 QFN-20
LTC4099*	1	1.5	4.35 to 5.5	Bat-Track Linear	✓	✓	✓	–	3x4 QFN-20
LTC4160-1	1	1.5	4.35 to 5.5	Bat-Track Linear	✓	–	✓	–	3x4 QFN-20
LTC1731-4.1	1	2	4.5 to 12	Linear	–	–	–	–	MSOP-8/SO-8
LTC1731-8.2	2	2	4.5 to 12	Linear	–	–	–	–	MSOP-8/SO-8
LTC1732-4	1, 2	2	4.5 to 12	Linear	–	–	–	–	MSOP-10
LTC4050-4.1/8.2	1	2	4.5 to 12	Linear	–	–	–	–	MSOP-10
LTC4001-1	1	2	4 to 5.5	Switch Mode	–	–	–	–	4x4 QFN-16
LT3650-4.1 [§] /8.2 [#]	1, 2	2	4.75 to 32	Switch Mode	–	–	–	–	3x3 DFN-12, MSOP-12E
LTC1980 [†]	1, 2	2	4.1 to 12	Switch Mode	–	–	–	–	SSOP-24
LTC4110 [†] *	1–4	3	6 to 20	Switch Mode/ Flyback	–	–	✓	–	5x7 QFN-38
LTC4155	1	3.5	4.35 to 5.5	Switch Mode	✓	–	✓	–	4x5 QFN-28
LT3651-4.1	1	4	4.8 to 32	Switch Mode	–	–	–	–	5x6 QFN-36
LT3651-8.2	2	4	9 to 32	Switch Mode	–	–	–	–	5x6 QFN-36
LT3652/HV	1–3/1–4	2	4.95 to 32 [§]	Switch Mode	–	–	–	–	3x4 DFN-12, MSOP-12E
LTC4007/-1	3, 4	4	6 to 28	Switch Mode	–	–	✓	–	SSOP-24
LTC4100 [†] *	2–6	4	6 to 28	Switch Mode	–	–	✓	–	SSOP-24
LTC4101 [†] *	1	4	6 to 28	Switch Mode	–	–	✓	–	SSOP-24
LTC4008 [†]	2–6	4	6 to 28	Switch Mode	–	–	✓	–	SSOP-20
LTC4009 [†] /-1	1–4	4	6 to 28	Switch Mode	–	–	–	–	4x4 QFN-20
LTC4012 [†] /-1/-3	1–4	4	6 to 28	Switch Mode	–	–	✓	–	4x4 QFN-20
LTC1760 [†] *	2–6	4	6 to 28	Switch Mode	–	–	✓	–	TSSOP-48
LTC1960 [†] *	2–6	8	6 to 28	Switch Mode	–	–	✓	–	5x7 QFN-38, SSOP-36

* [†] 2°C Controlled, [†] Programmable, [‡] SEL Pin = 0V Programs for 4.1V or 4.2V, [§] 7.5V Start-up Voltage for 1-Cell Operation, [#] 11.5V Start-up Voltage, [¶] 500mA with External PFET

Low Current/Coin Cell Battery Chargers

Our coin cell battery chargers enable highly accurate charging of low capacity, charge-sensitive coin cells used in thin, compact devices such as Bluetooth headsets and hearing aids.



LTC4054L: 150mA Standalone Li-Ion Battery Charger for Coin Cells

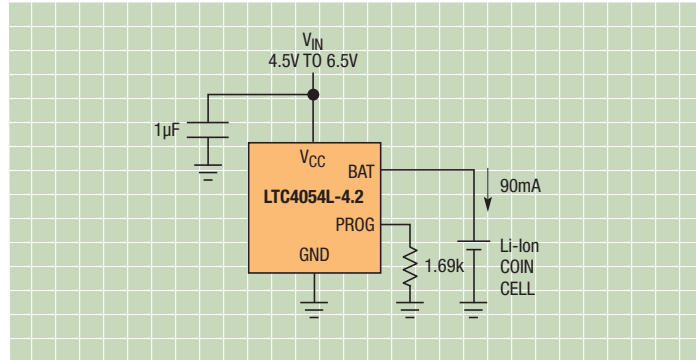

90mA Li-Ion Coin Cell Charger

LTC4065L: 250mA Standalone Linear Li-Ion Battery Charger in 2mm x 2mm DFN

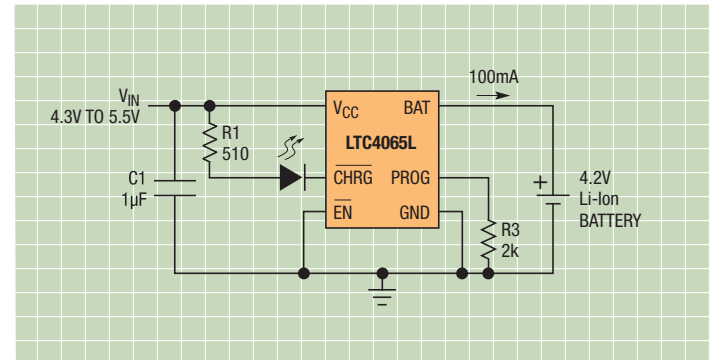

Standalone Li-Ion Charger

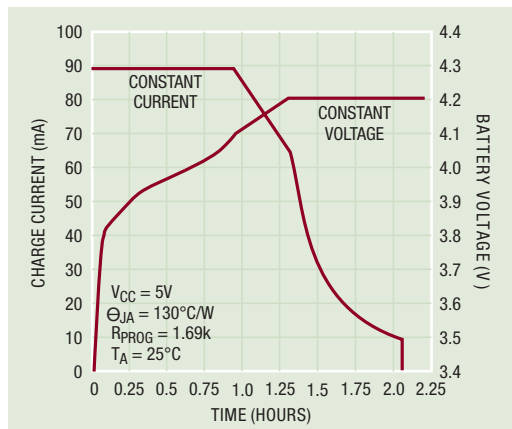

LTC4054L Complete Charge Cycle

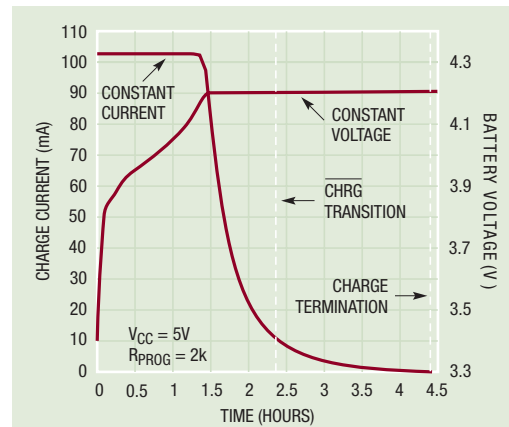

LTC4065L Complete Charge Cycle

Part Number	Charge Current Range (mA)	Input Voltage (V)	Battery Charger Type	Standalone	Charge Termination (Plus Indication)	Thermal Regulation	Integrated Power Transistor	Package (mm x mm)
Coin Cell Li-Ion Battery Chargers								
LTC4070	0.001-50 [†]	Unlimited	Shunt	✓	✓	—	✓	2x3 DFN-8 MSOP-8E
LTC4071	0.001-50	Unlimited	Shunt	✓	✓	—	✓	2x3 DFN-8 MSOP-8E
LTC4054L	10-150	4.25 to 6.5	Linear	✓	C/10	✓	✓	ThinSOT
LTC1734L	10-180	4.55 to 8	Linear	—	—	—	External	ThinSOT
LTC4065L/LX*	15-250	3.75 to 5.5	Linear	✓	Timer + C/10	✓	✓	2x2 DFN-6
LTC4059/A	90-900	3.75 to 8	Linear	—	—	✓	✓	2x2 DFN-6

* "X" (No Trickle Charge) Versions Useful when the System Load Exceeds the Trickle Charge Current at Very Low Battery Voltages, [†] 500mA with ext PFET

NiMH and NiCd Battery Chargers

Our nickel battery chargers reduce component count, speed design and allow fast, accurate and reliable charging of both NiMH and NiCd cells.



LTC4060:
Actual Size
Demo Circuit

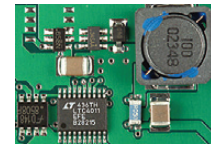

LTC4011:
Actual Size
Demo Circuit

LTC4060: Standalone 2A Linear NiMH/NiCd Fast Battery Charger

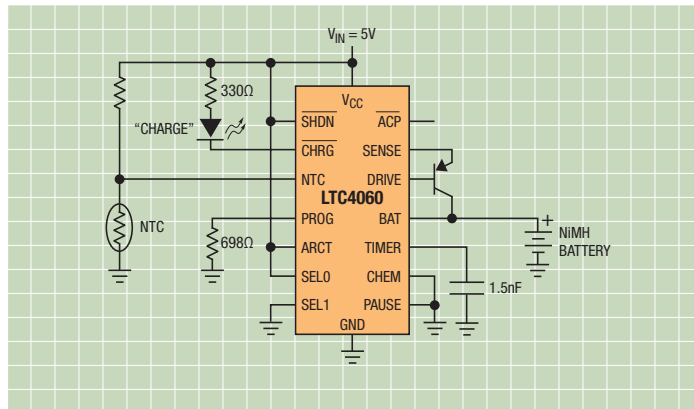

2-Cell, 2A Standalone NiMH Fast Charger with Optional Thermistor and Charge Indicator

LTC4011: High Efficiency 4A Standalone Switch Mode Battery Charger with Analog INFET Control

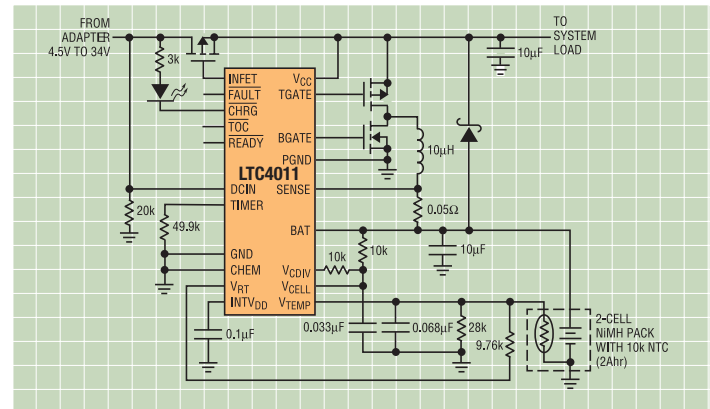

2A NiMH Battery Charger

Part Number	Topology	Number of Battery Cells* (Series)	Maximum Charge Current (A)	Input Voltage (V)	Charge Termination	Integrated Power Transistor	End-of-Charge Signal	AC Present Signal	Thermistor Interface	Package (mm x mm)
NiMH/NiCd Battery Chargers – Standalone										
LTC4060	Linear	1–4	2	4.5 to 10	-dV, t, V, T	–	✓	✓	✓	3x5 DFN-16, TSSOP-16
LTC4010	Synchronous Step-Down	1–16	4	4.5 to 34	-dV, dT/dt, T, t	–	✓	✓	✓	TSSOP-16E
LTC4011†	Synchronous Step-Down	1–16	4	4.5 to 34	-dV, dT/dt, T, t	–	✓	✓	✓	TSSOP-20E
NiMH/NiCd Battery Chargers – Non-Standalone										
LT1512	SEPIC	1–12	0.8	2.4 to 29	External μC	✓	–	–	–	SO-8
LT1510	Step-Down	1–12	1	7 to 29	External μC	✓	–	–	–	SO-8, SSOP-16, SO-16
LT1513	SEPIC	1–12	1.6	2.4 to 29	External μC	✓	–	–	–	DD Pak, TO-220
LT1769	Step-Down	1–12	2	7 to 29	External μC	✓	–	–	–	TSSOP-20, SSOP-28
LT1511	Step-Down	1–12	3	7 to 29	External μC	✓	–	–	–	SO-24
LTC4008	Synchronous Step-Down	4–14	4	6 to 28	External μC	–	✓	✓	✓	SSOP-28
LTC4009/-1/-2	Synchronous Step-Down	2–14	4	6 to 28	External μC	–	✓	✓	–	4x4 QFN-20
LTC4012/-1/-2/-3†	Synchronous Step-Down	2–14	4	6 to 28	External μC	–	✓	✓	–	4x4 QFN-20
LT1505	Synchronous Step-Down	1–12	8	6.7 to 26	External μC	–	✓	–	–	SSOP-28
LTC1960	Step-Down	4–16	8	6 to 28	External μC, SPI	–	–	–	–	5x7 QFN-38, SSOP-36
NiMH/NiCd Battery Chargers – Smart Chargers (SMBus)										
LTC4110	Synchronous Flyback	up to 10	3	6 to 20	Smart Battery, External μC	–	–	✓	✓	5x7 QFN-38
LTC4100	Step-Down	1–13	4	6 to 28	Smart Battery, External μC	–	–	✓	✓	SSOP-24
LTC4101	Step-Down	2–3	4	6 to 28	Smart Battery, External μC	–	–	✓	✓	SSOP-24
LTC1759	Step-Down	1–13	8	11 to 24	Smart Battery, External μC	–	–	✓	✓	SSOP-36

*Based on Maximum Cell Voltage of 1.8V, † Includes PowerPath Control

USB Power Managers: Battery Chargers with PowerPath Control

PowerPath products and architectures permit the load to be powered from both V_{IN} and the battery, enabling shorter charge time, instant-on operation (even with a dead or missing battery) and more flexibility for the portable device designer. Other key features include standalone operation and thermal regulation.

LTC4098:
Actual Size
Demo Circuit



LTC4090:
Actual Size
Demo Circuit

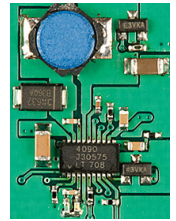

LTC4098/-1: USB Power Manager with Overvoltage Protection

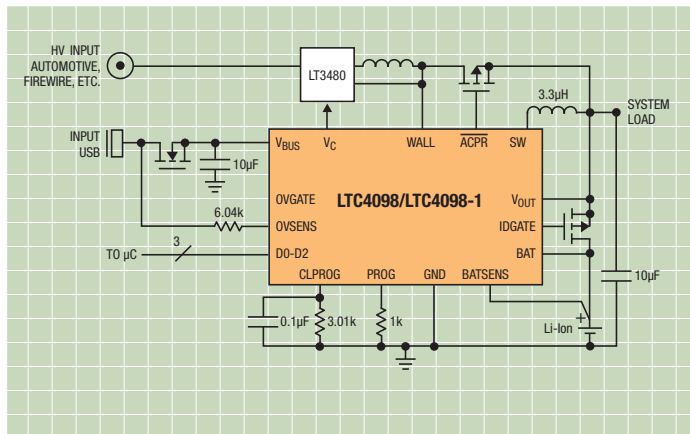

High Efficiency USB/Automotive Power Manager with Overvoltage Protection

LTC4090: USB Power Manager with 2A High Voltage Bat-Track Buck Regulator

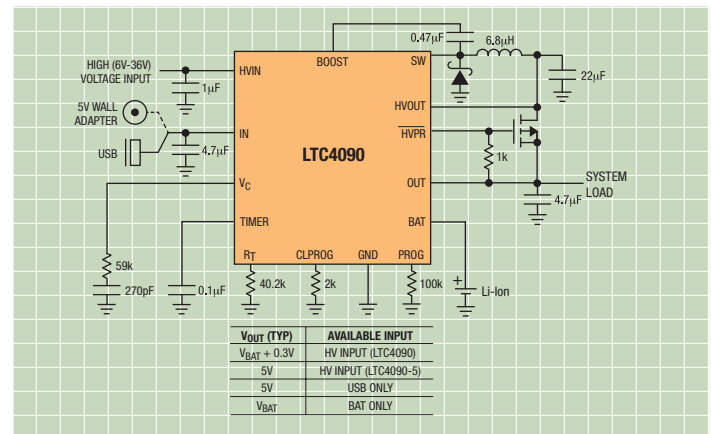

High Voltage USB Power Manager with Bat-Track Adaptive Output Control

Part Number	Number of Battery Cells (Series)	Max Charge Current from Wall (A)	Max Charge Current from 500mA USB (mA)	Input Voltage (V)	Power Manager Topology	Charge Termination (Plus Indication)	Ideal Diode RdsON	Package (mm x mm)
USB Power Managers and Li-Ion/Polymer Linear Battery Chargers with PowerPath Control								
LTC4055/-1*	1	1	500	4.35 to 5.5	Linear	Timer	200mΩ	4x4 QFN-16
LTC4089*	1	1.2	500	4.35 to 5.5 USB, 6-36, 40 Max Wall	Linear	Timer + C/10	215mΩ, (<50mΩ Opt.)	3x6 DFN-22
LTC4089-5	1	1.2	500	4.35 to 5.5 USB, 6-36, 40 Max Wall	Linear	Timer + C/10	215mΩ, (<50mΩ Opt.)	3x6 DFN-22
LTC4089-1**†	1	1.2	500	4.35 to 5.5 USB, 6-36, 40 Max Wall	Linear	Timer + C/10	215mΩ, (<50mΩ Opt.)	3x6 DFN-22
LTC4090*	1	1.2	500	4.35 to 5.5 USB, 6-38, 60 Max Wall	Linear	Timer + C/10	215mΩ, (<50mΩ Opt.)	3x6 DFN-22
LTC4090-5	1	1.2	500	4.35 to 5.5 USB, 6-36, 60 Max Wall	Linear	Timer + C/10	215mΩ, (50mΩ Opt.)	3x6 DFN-22
LTC4067	1	1.25	500	4.35 to 5.5, 13 OVP	Linear	Timer + C/10	200mΩ, (<50mΩ Opt.)	3x4 DFN-12
LTC4066/-1†	1	1.5	500	4.35 to 5.5, USB + Wall Inputs	Linear	Timer + C/x	50mΩ	4x4 QFN-24
LTC4085/-1†	1	1.5	500	4.35 to 5.5, USB + Wall Inputs	Linear	Timer + C/10	215mΩ, (<50mΩ Opt.)	3x4 DFN-14
LTC4088/-1/-2*	1	1.5	700	4.35 to 5.5	Switch Mode	Timer + C/x	180mΩ, (<50mΩ Opt.)	3x4 DFN-14
LTC4098/-1**†	1	1.5	700	4.35 to 5.5 USB, 66 OVP, Wall = 5V Adapter or Buck High-V	Switch Mode	Timer + C/x	180mΩ, (<50mΩ Opt.)	3x4 QFN-20
LTC4098-3.6*#	1	1.5	700	4.35 to 5.5 USB, 66 OVP, Wall = 5V Adapter or Buck High-V	Switch Mode	Timer + C/x	180mΩ, (<50mΩ Opt.)	3x4 QFN-20
LTC4160/-1**§	1	1.5	700	4.35 to 5.5 USB, 66 OVP	Switch Mode	Timer + C/x	180mΩ, (<50mΩ Opt.)	3x4 QFN-20
LTC4099*‡	1	1.5	700	4.35 to 5.5 USB, 66 OVP	Switch Mode	Timer + C/x	180mΩ, (<50mΩ Opt.)	3x4 QFN-20
LTC4155*§**	1	3.5	700	4.35 to 5.5 USB, 77 OVP	Switch Mode	Timer + C/x	180mΩ	4x5 QFN-28
LTC4156*#§**	1	3.5	700	4.35 to 5.5 USB, 77 OVP	Switch Mode	Timer + C/x	180mΩ	4x5 QFN-28

* Bat-Track Adaptive Output Control, † 4.1V Cell Voltage, ‡ I²C Controlled, Selectable 4.1V/4.2V Float Voltage, § USB On-The-Go, # For 1-cell Lithium Iron Phosphate (LiFePO₄) Batteries, ** I²C Controlled, Selectable Float Voltage

PMICs: Switch Mode Power Manager-Based

Our power management integrated circuits (PMICs) address battery charging and multiple system power rail needs for single-cell lithium-ion/polymer portable products. Switch mode power management enables higher efficiency charging, less heat dissipation and compatibility with wall adapter, USB and high voltage power sources.

LTC3556: High Efficiency Switch Mode USB Power Manager + Battery Charger + Dual Step-Down DC/DC + Buck-Boost + LDO

Features:

Power Manager

- High Efficiency Switching PowerPath Controller with Bat-Track Adaptive Output Control
- Programmable USB or Wall Current Limit (100mA/500mA/1A)
- Full Featured Li-Ion/Polymer Battery Charger
- 1.2A Maximum Charge Current
- Internal 180m Ω Ideal Diode + External Ideal Diode Controller Powers Load in Battery Mode
- Low No-Load Quiescent Current when Powered from BAT (<30 μ A)

DC/DCs

- Dual High Efficiency Step-Down DC/DCs (400mA/400mA I_{OUT})
- High Efficiency Buck-Boost DC/DC (1A I_{OUT})
- All Regulators Operate at 2.25MHz
- Dynamic Voltage Scaling on Two Buck Outputs
- I^2C Control of Enables, MODE, Two V_{OUT} Settings
- Low No-Load Quiescent Current: 20 μ A
- Always-On, 3.3V/25mA LDO
- Low Profile 4mm \times 5mm 28-Pin QFN Package

Applications:

- HDD-Based MP3 Players, PDAs, PMPs
- PNDs, DMB/DVB-H; Digital/Satellite Radio
- Portable Industrial/Medical Products
- Universal Remotes, Photo Viewers
- Other USB-Based Handheld Products

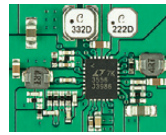

LTC3556:
Actual Size
Demo Circuit

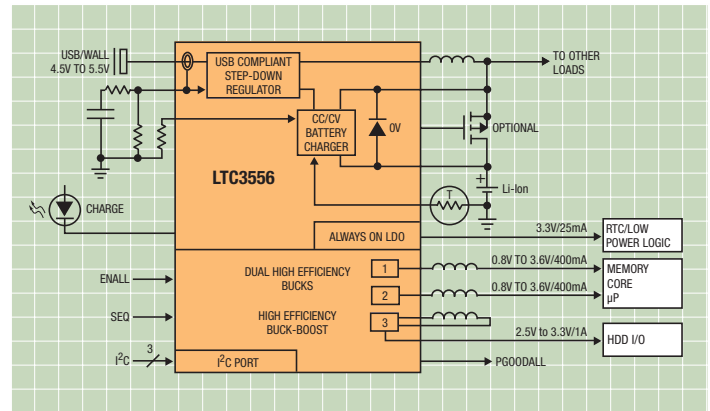

High Efficiency PowerPath Manager, Dual Buck, Buck-Boost and LDO

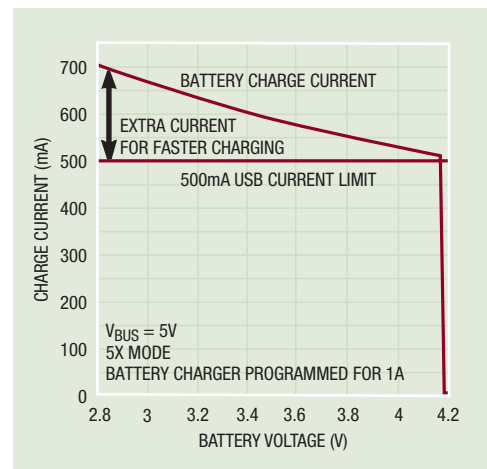

Battery Charge Current from USB

Part Number	Number of Regulators	Input Voltage (V)	Buck(s) (I_{OUT})	Buck-Boost (I_{OUT})	Boost (I_{OUT})	LDO(s) (I_{OUT})	Li-Ion/ Polymer Charger	Max Charge Current (A)	Ideal Diode	Interface	Package (mm x mm)
Switch Mode PowerPath Management Integrated Circuits (PMICs)											
LTC3566	2	4.35 to 5.5	–	1A	–	3.3V/25mA	✗	1.5	Int + Ext (Opt.)	Simple	4x4 QFN-24
LTC3567	2	4.35 to 5.5	–	1A	–	3.3V/25mA	✗	1.5	Int + Ext (Opt.)	I^2C	4x4 QFN-24
LTC3555/-1/-3*	4	4.35 to 5.5	1A, 400mA x 2	–	–	3.3V/25mA	✗	1.5	Int + Ext (Opt.)	I^2C	4x5 QFN-28
LTC3556	4	4.35 to 5.5	400mA x 2	1A	–	3.3V/25mA	✗	1.5	Int + Ext (Opt.)	I^2C	4x5 QFN-28
LTC3576/-1**	4	4.35 to 5.5, High-V, OVP	1A, 400mA x 2	–	–	3.3V/20mA	✗	1.5	Int + Ext (Opt.)	I^2C	4x6 QFN-38
LTC3586/-1*	5	4.35 to 5.5	400mA x 2	1A	0.8A	3.3V/20mA	✗	1.5	Int + Ext (Opt.)	Simple	4x6 QFN-38

* 4.1V Battery Float Voltage, † See Page 12 for Compatible High Voltage Buck Regulators

PMICs: Linear Power Manager-Based

Our power management integrated circuits (PMICs) address battery charging and multiple system power rail needs in single-cell lithium-ion/polymer portable products. Linear power management allows seamless transition and manages power flow between input power sources such as a wall adapter, USB port, lithium battery and the system load.

LTC3577/-1: Highly Integrated 6-Channel PMIC

Features:

- Full Featured Li-Ion Charger/PowerPath Controller with Instant-On Operation
- High Temperature Battery Voltage Reduction Improves Safety and Reliability
- 1.5A Maximum Charge Current with Thermal Limiting
- Pushbutton On/Off Control with System Reset
- Dual 150mA Current Limited LDOs
- Triple Adjustable High Efficiency Step-Down Switching Regulators (600mA, 400mA, 400mA I_{OUT})
- 200mΩ Internal Ideal Diode Plus External Ideal Diode Controller Provides Low Loss Power Path from Battery
- Bat-Track Control for External HV Buck DC/DCs
- I²C Adjustable SW Slew Rates for EMI Reduction
- Overvoltage Protection for USB (VBUS)/Wall Input
- Integrated 40V Series LED Driver with 60dB Brightness and Gradation Control via I²C
- Small 4mm × 7mm 44-Pin QFN Package

Applications:

- PNDs, DMB/DVB-H; Digital/Satellite Radio
- Portable Industrial/Medical Products
- Universal Remotes, Photo Viewers
- Other USB-Based Handheld Products

LTC3577: Actual Size, Complete Solution

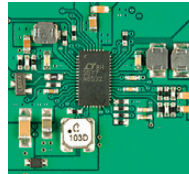

Solution Size = 22mm x 15mm

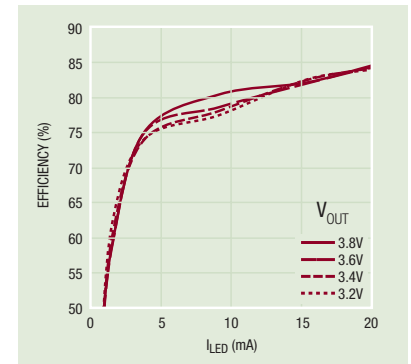

LED Driver Efficiency (10 LEDs)

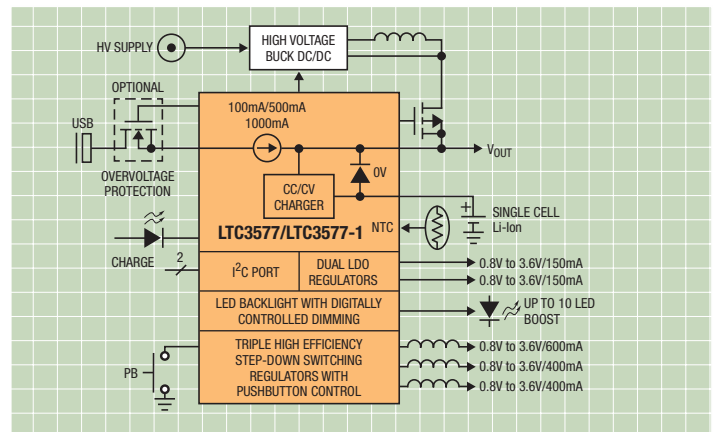

USB Plus HV Input Charger and Multichannel PMIC

Part Number	Number of Regulators	Input Voltage (V)	Buck(s) (I _{OUT})	LDO(s)	Li-Ion/ Polymer Charger	Max Charge Current	PowerPath Topology	Ideal Diode	Interface	Package (mm x mm)
Linear PowerPath Management Integrated Circuits (PMICs)										
LTC3553	2	4.35V to 5.5V	200mA	150mA	✓	500mA	✓	✓	–	3x3 QFN-20
LTC3554	2	4.35V to 5.5V	200mA x 2	–	✓	500mA	✓	✓	–	3x3 QFN-20
LTC3455	3	2.7 to 5.5, USB + Wall Inputs	400mA, 600mA [‡]	Controller	✓	500mA	✓	–	–	4x4 QFN-24
LTC3557/-1 [§]	4	2.7 to 5.5, USB, High-V Bat-Track (*)	600mA, 400mA x 2	3.3V/25mA	✓	1.5A	✓	Int + Ext (Opt.)	–	4x4 QFN-28
LTC3577/-3 LTC3577-1/-4 [§]	6 [#]	2.7 to 5.5, USB, High-V Bat-Track (*), OVP	800mA, 500mA x 2	2x150mA	✓	1.5A	✓	Int + Ext (Opt.)	–	4x7 QFN-44
LTC3677-3 [¶]	6	2.7 to 5.5, USB, High-V Bat-Track (*), OVP	800mA, 500mA x 2	2x150mA	✓	1.5A	✓	Int + Ext (Opt.)	–	4x7 QFN-44

* See Table Below for Compatible High Voltage Buck Regulators, † Includes 50mA Hot Swap™ Controller, ‡ May be Increased to 1A with Additional Components, § 4.1V Battery Float Voltage, # Includes 10-LED Boost, ¶ No LED Driver

Part Number	Input Voltage, Maximum (V)	Efficiency (%)	I _{SW} /I _{OUT} (A)	Switching Frequency	Reference Voltage (V)	Inductor (µH)	Output Capacitor (µF)	Quiescent Current	I _{SD} (µA)	Package (mm x mm)
*High Voltage Buck Regulators (Compatible with LTC3557, LTC3576 and LTC3577)										
LT3505	3.6-36, 40	>85	1.75 / 1.2	300k-3MHz	0.78	6.8	10-Ceramic	2mA	<2	3x3 DFN-8, MSOP-8E
LT3480	3.6-38, 60	>85	3 / 2	200k-2MHz	0.79	4.7	22-Ceramic	70µA	<1	3x3 DFN-10, MSOP-10E
LT3481	3.6-34, 36	>85	3.2 / 2	300k-2.8MHz	1.26	4.7	22-Ceramic	50µA	<1	3x3 DFN-10, MSOP-10E
LT3653	7.5-30, 60	>85	2 / 1.2	1.5MHz	n/a	4.7	10-Ceramic	2.8mA	n/a	2x3 DFN-8

PMICs: Linear Battery Charger (Battery-Fed)

Our power management integrated circuits (PMICs) address battery charging and multiple system power rail needs in single-cell lithium portable products. A high level of integration is offered in a small footprint for a compact total solution size and ease-of-use.

LTC3558: Linear USB Battery Charger with Buck-Boost and Buck Regulators

Features:

Power Manager

- Standalone USB Charger
- Up to 950mA Charge Current Programmable via Single Resistor
- HPWR Input Selects 20% or 100% of Programmed Charge Current
- NTC Input for Temperature Qualified Charging
- Internal Timer Termination
- Bad Battery Detection

Switching Regulators

- 400mA Output Current per Regulator
- 2.25MHz Constant Frequency Operation
- Power Saving Burst Mode® Operation
- Low Profile 3mm × 3mm 20-Pin QFN Package

Applications:

- PNDs, DMB/DVB-H; Digital/Satellite Radio
- SD/Flash-Based MP3 Players
- Portable Industrial/Medical Products
- Universal Remotes, Photo Viewers
- Other USB-Based Handheld Products
- Low Power Handheld Applications

LTC3558: Actual Size, Complete Solution

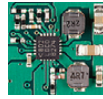

Solution Size =
12mm x 11mm

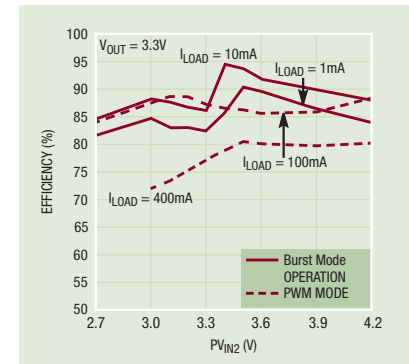

Buck-Boost Regulator Efficiency vs Input Voltage

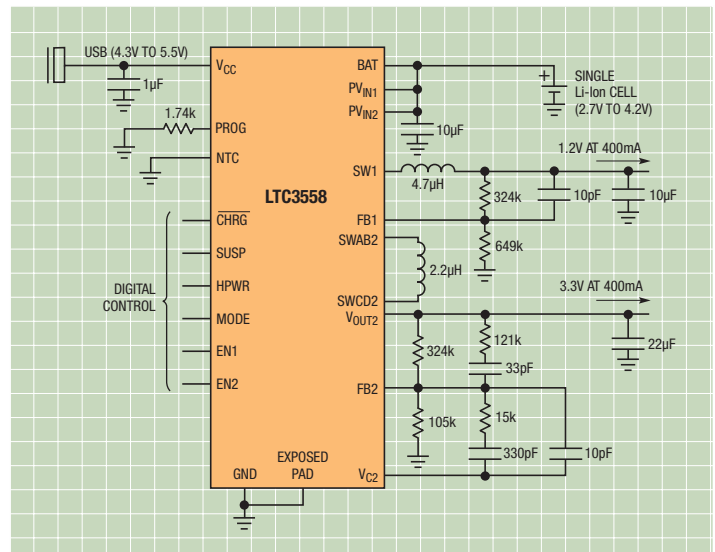

USB Charger Plus Buck Regulator and Buck-Boost Regulator

Part Number	Number of Regulators	Maximum Charge Current (mA)	Input Voltage (V)	Buck(s) (I _{OUT})	Buck-Boost(s) (I _{OUT})	Li-Ion/Polymer Charger	PowerPath Topology	Package (mm x mm)
Power Management Integrated Circuits (PMICs), Charger-Fed								
LTC4080	1	500	2.7 - 4.5	300mA	—	✓	—	3x3 DFN-10, MSOP-10E
LTC4081	1	500	2.7 - 4.5	300mA	—	✓	—	3x3 DFN-10
LTC3550/-1	1	950	2.5 - 5.5	600mA	—	✓	—	3x5 DFN-16
LTC3552/-1	2	950	2.5 - 5.5	400mA/800mA	—	✓	—	3x5 DFN-16
LTC3558	2	950	3.0 - 4.2	400mA	400mA	✓	—	3x3 QFN-20
LTC3559	2	950	3.0 - 4.2	400mA x 2	—	✓	—	3x3 QFN-16

Switch Mode Buck Battery Chargers

Our step-down (buck) battery chargers enable high efficiency charging from a wide input voltage range for a variety of battery chemistries.

LT3651: Monolithic 4A High Voltage Li-Ion Battery Charger

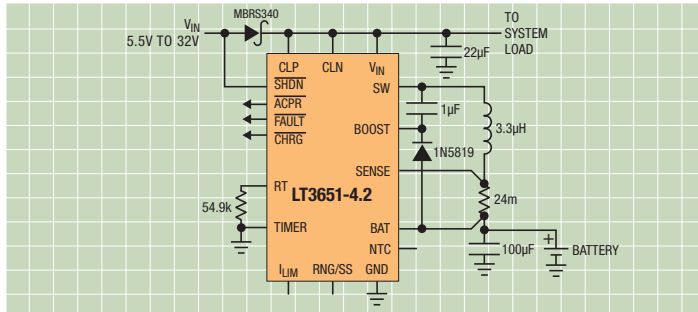

7.5V to 32V Single Cell 4A Charger

LT3652HV: Power Tracking 2A Battery Charger

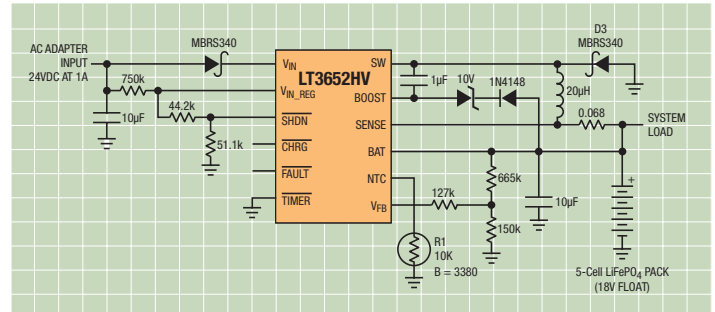

24V 5-Cell LiFePO₄ Charger (18V at 1.5A) with C/10 Termination

Part Number	Maximum Charge Current (A)	V _{BAT} Range (V)	Battery Chemistry	Number of Battery Cells (Series)	Input Voltage (V)	Integrated Power Transistor	Synchronous	Charge Termination	Package (mm x mm)
Switch Mode Multichemistry Buck (Step-Down) Battery Chargers									
LT1510	1	2.5 to 26	NiMH NiCd SLA Li-Ion	1-12 Ni, SLA 1-4 Li-Ion	7 to 29	✓	–	External µC or LTC1729	SO-8, SSOP-16, SO-16
LT3652	2	3.3 to 14.4	SLA LiFePO ₄ Li-Ion	SLA 1-4 LiFePO ₄ 1-3 Li-Ion	4.9 to 32 [†]	✓	–	Timer or C/10	3x3 DFN-12, MSOP-12E
LT3652HV	2	3.3 to 18	SLA LiFePO ₄ Li-Ion	SLA 1-5 LiFePO ₄ 1-4 Li-Ion	4.9 to 34 [†]	✓	–	Timer or C/10	3x3 DFN-12, MSOP-12E
LT1769	2	2.5 to 26	NiMH NiCd SLA Li-Ion	1-12 Ni, SLA 1-4 Li-Ion	7 to 29	✓	–	External µC or LTC1729	TSSOP-20 SSOP-28
LT1511	3	2.5 to 26	NiMH NiCd SLA Li-Ion	1-12 Ni, SLA 1-4 Li-Ion	7 to 29	–	–	External µC or LTC1729	SO-24
LTC4008	4	3 to 28	NiMH NiCd SLA Li-Ion	4-18 Ni, SLA 2-6 Li-Ion	6 to 28	–	✓	External µC	SSOP-20
LTC4009/-1*/-2 [†]	4	2 to 28	NiMH NiCd SLA Li-Ion	2-18 Ni, 1-6 Li-Ion	6 to 28	–	✓	External µC	4x4 QFN-20
LTC4012/-1*/-2 [†] /-3	4	2 to 28	NiMH NiCd SLA Li-Ion	2-18 Ni, 1-6 Li-Ion	6 to 28	–	✓	External µC	4x4 QFN-20
LT1505	8	2.5 to 23	NiMH NiCd SLA Li-Ion	1-12 Ni, SLA 1-4 Li-Ion	11 to 26	–	✓	External µC	SSOP-28
LTC1960	8	3.5 to 28	NiMH NiCd SLA Li-Ion	4-16 Ni, SLA 2-6 Li-Ion	6 to 28	–	✓	External µC	5x7 QFN-38, SSOP-36
Switch Mode Li-Ion Buck Battery Chargers									
LT1571	1.5	2.5 to 26	Li-Ion	1-2, Adj	6.2 to 27	✓	–	External µC	SSOP-16 SSOP-28
LTC4001/-1*	2	4.2	Li-Ion	1	4 to 5.5	✓	✓	Timer	3x3 QFN-16
LT3650-4.1/-4.2	2	4.1, 4.2	Li-Ion	1	4.75 to 32 [†] (40 Max)	✓	–	Timer + C/10	3x3 DFN-12 MSOP-12E
LT3650-8.2/-8.4	2	8.2, 8.4	Li-Ion	2	9 to 32 [†] (40 Max)	✓	–	Timer + C/10	3x3 DFN-12 MSOP-12E
LT3651-4.1/4.2	4	4.1, 4.2	Li-Ion	1	4.8 to 32	✓	✓	Timer + C/10	5x6 QFN-36
LT3651-8.2/8.4	4	8.2, 8.4	Li-Ion	2	9 to 32	✓	✓	Timer + C/10	5x6 QFN-36
LTC4002-4.2/-8.4	4	4.2, 8.4	Li-Ion	1-2	4.7 to 22	–	–	Timer	3x3 DFN-10 SO-8
LTC4006-2/-4/-6	4	5 to 16.8	Li-Ion	2-4	6 to 28	–	✓	Timer	SSOP-16
LTC4007/-1	4	7.5 to 16.8	Li-Ion	3-4	6 to 28	–	✓	Timer	SSOP-24

* 4.1V Cell Voltage † Minimum Start-Up Voltage is + 3.3V Above V_{BATMAX} ‡ -1 and -2 Versions are Fixed Voltage Options for 1-4 Li-Ion Cells

Switch Mode Buck-Boost Battery Chargers

Our buck-boost battery chargers seamlessly charge a battery as its voltage varies below, above or equal to the input voltage.

LTC4110: Battery Backup System Manager

Package: 5mm x 7mm QFN-38

Features:

- Complete Backup Battery Manager for Li-Ion/ Polymer, Lead Acid, NiMH/NiCd Batteries and Supercapacitors
- Charge and Discharge Battery with Voltages Above and Below the Input Supply Voltage
- “No Heat” Battery Calibration Discharge Using System Load
- Automatic Battery Backup with Input Supply Removal Using PowerPath Control
- Standalone for Li-Ion/Polymer, SLA, and Supercapacitors
- Optional SMBus Support Allows Battery Capacity Calibration Operation with Host
- Over- and Under-Battery Voltage Protection
- Adjustable Battery Float Voltage
- Programmable Charge/Calibration Current Up to 3A with $\pm 3\%$ Accuracy
- Wide Backup Battery Supply Range: 2.7V to 19V
- Wide Input Supply Range: 4.5V to 19V

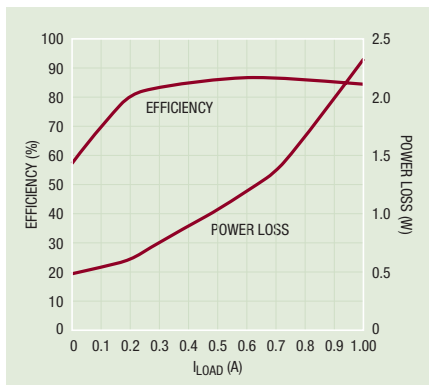

Charging Efficiency/Power Loss, 12V_{IN} and 12.6V_{OUT}

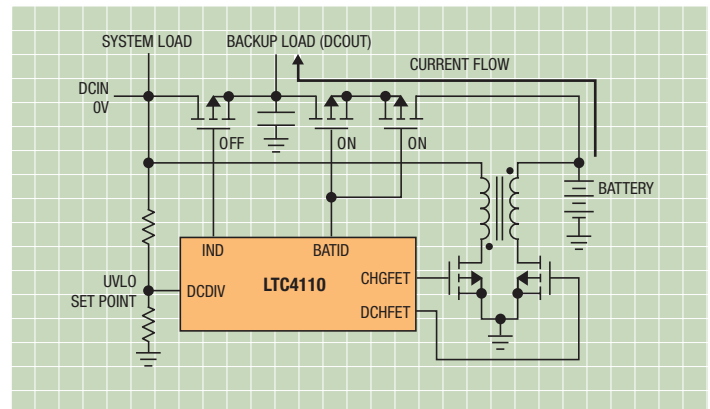

Battery Backup System Manager

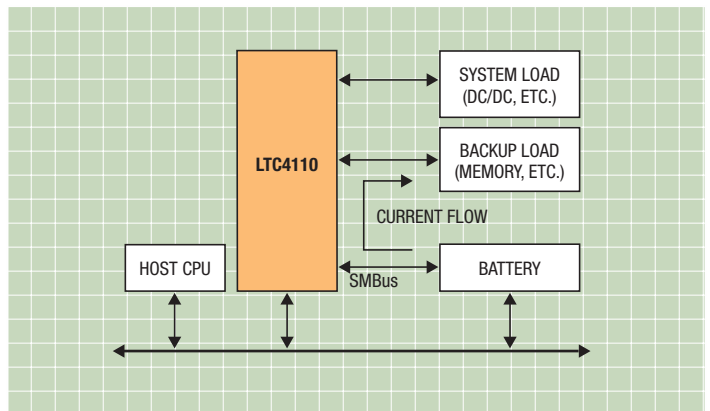

Server Backup System (In Backup Mode)

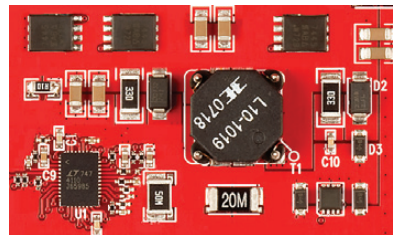

LTC4110:
Actual Size
Demo Circuit

Part Number	Number of Battery Cells (Series)	Maximum Charge Current (A)	V _{BAT} Range (V)	Battery Chemistry	Input Voltage (V)	Integrated Power Transistor	Synchronous	Charge Termination	Package (mmxmm)
Switch Mode Buck-Boost (Step-Down/Step-Up) Battery Chargers									
LT1512	1-12 Ni	0.8	1.5 to 20	NiCd NiMH SLA	2.4 to 29	✓	–	External μ C	S0-8
LT1513	1-12 Ni	1.6	1.5 to 20	NiCd NiMH SLA	2.4 to 29	✓	–	External μ C	DD Pak, TO-220
LTC1980	1-2 Li	4	2.85 to 10	NiCd NiMH Li-Ion	4.1 to 12	–	–	External μ C, Timer (Li)	SSOP-24
LTC4110 **	Up to 10 Ni, 1-4 Li, Up to 6 SLA	4	3.5 to 18	NiCd NiMH SLA, Li-Ion	6 to 19	–	✓	Timer, C/10, SMBus	5x7 QFN-38

* Flyback Topology, † Supercapacitor Compatible

Ideal Diodes/PowerPath Controllers

Our Ideal Diode devices provide a low loss, near “ideal” diode function. They feature much lower forward voltage drop and reverse leakage current than conventional Schottky diodes. This reduces power loss and eases thermal management while extending battery run time.

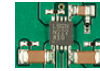

LTC4413:
Actual Size
Demo Circuit

LTC4413: Dual 2.6A, 2.5V to 5.5V Ideal Diodes in 3mm x 3mm DFN

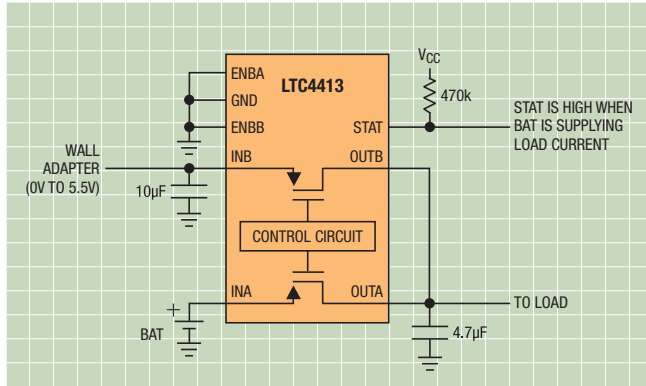

Monolithic Dual Ideal Diode

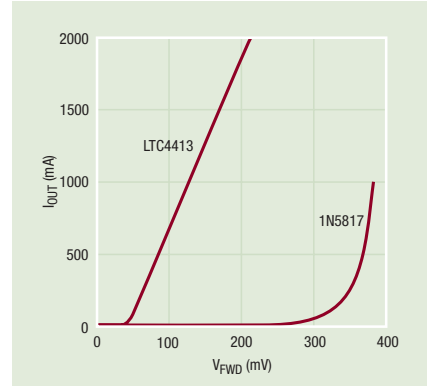

LTC4413 vs 1N5817 Schottky

Part Number	Ideal Diode	External MOSFET	Integrated MOSFET	Maximum Current (A)	Input Voltage (V)	Forward Voltage (mV)	Forward ON Resistance	Reverse Leakage Current (µA)	Supply Current (µA)	Package (mmxmm)
P-Channel PowerPath/Ideal Diode Controllers										
LTC4411	Single	P-Channel	✓	1	2.6 to 5.5	28	140mΩ	1	35	ThinSOT
LTC4412	Single	P-Channel	–	2*	2.5 to 28	20	Controller	3	13	ThinSOT
LTC4412HV	Single	P-Channel	–	2*	2.5 to 36	20	Controller	3	13	ThinSOT
LTC4413/-1†	Dual	P-Channel	✓	2.6	2.5 to 5.5	28	100mΩ	1	20	3x3 DFN-10
LTC4413-2†	Dual	P-Channel	✓	2.6	2.5 to 5.5, 13 OVP	28	100mΩ	1	20	3x3 DFN-10
LTC4414	Single	P-Channel	–	5-75*	3 to 36	22	Controller	3	33	MSOP-8
LTC4416/-1	Dual	P-Channel	–	5-75*	3.6 to 36	22	Controller	3	70	MSOP-10

* Depends on MOSFET Selection, † High Speed Version

LTC4352: MOSFET Diode-OR Controller

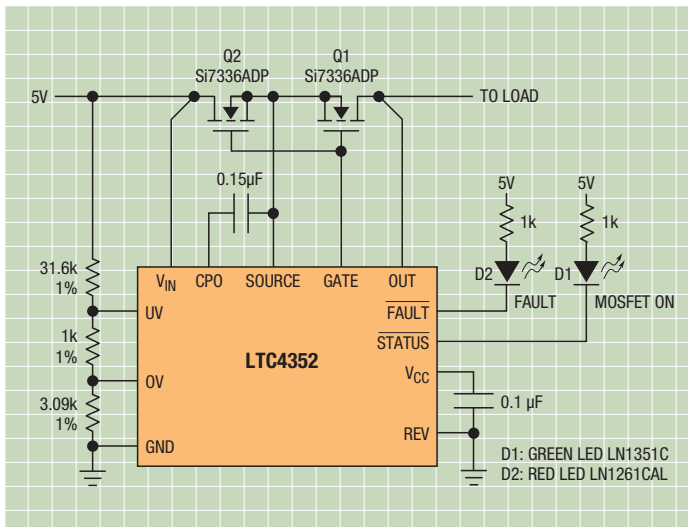

5V Ideal Diode Circuit with Input Undervoltage and Overvoltage Protection

Part No.	Ideal Diode	External MOSFET	Maximum Current (A)	Input Voltage (V)	Package (mmxmm)
N-Channel PowerPath/Ideal Diode Controllers					
LTC4352	Single	N-Channel	≥5*	0 to 18	3x3 DFN-12, MSOP-12
LTC4357	Single	N-Channel	≥5*	9 to 80	2x3 DFN-6, MSOP-8
LTC4358	Single	N-Channel (Internal)	5	9 to 26.5	4x3 DFN-14 TSSOP-16
LTC1473	Dual	N-Channel	≥5*	4.75 to 30	SSOP-16
LTC1473L	Dual	N-Channel	≥5*	2.8 to 9	SSOP-16
LTC2952†	Dual	N-Channel	≥5*	2.7 to 28	TSSOP-20 4x4 QFN-20
LTC4354	Dual	N-Channel	≥5*	-4.5 to -100 (Floating)	3x2 DFN-8, SOIC-8
LTC4355	Dual	N-Channel	≥5*	9 to 80	4x3 DFN-14, SOIC-16
LTC1479	Triple	N-Channel	≥5*	6 to 28	SSOP-36

* Depends on MOSFET Selection, † Pushbutton PowerPath Controller with Supervisor

Supercapacitor Chargers

LTC3625/-1: 1A High Efficiency 2-Cell Supercapacitor Chargers with Automatic Cell Balancing

Package: 3mm x 4mm DFN-12

Features:

- High Efficiency Step-Up/Step-Down Charging of Two Series Supercapacitors
- Automatic Cell Balancing Prevents Capacitor Overvoltage During Charging
- Programmable Charging Current Up to 500mA (Single Inductor), 1A (Dual Inductor)
- $V_{IN} = 2.7V$ to 5.5V
- Selectable 2.4V/2.65V Regulation per Cell (LTC3625)
- Selectable 2V/2.25V Regulation per Cell (LTC3625-1)
- Low No-Load Quiescent Current: 23 μ A
- $I_{VOUT}, I_{VIN} < 1\mu$ A in Shutdown
- Low Profile 12-Lead 3mm x 4mm DFN Package

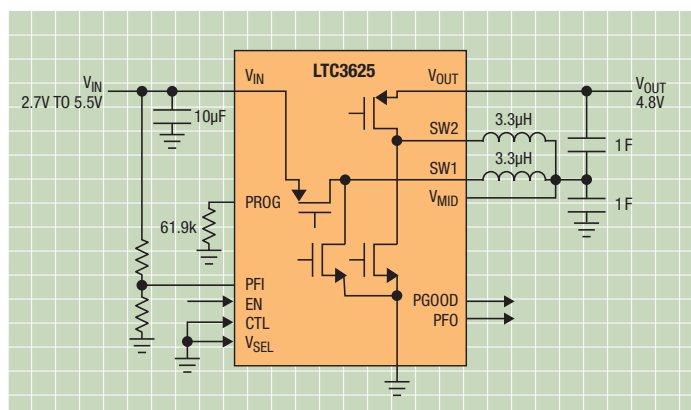

1A Supercapacitor Charger

Part Number	Topology	Input Voltage (V)	VCAP (Max) (V)	Quiescent Current (μ A)	Charge Current	Power Path	Automatic SCap Balancing	SCap Overvoltage Protection	Package
Supercapacitor Chargers									
LTC3225 LTC3225-1	Charge Pump-Boost	2.8-5.5	5.5	20	150mA	—	✘ [‡]	✘	2x3 DFN-10
LTC3625 LTC3625/-1	Switching Buck & Boost	2.7-5.5	5.5	23	1A*	—	✘ [‡]	✘	3x4 DFN-12
LTC4425	Linear	2.7-5.5	5.5	20	2A	— [†]	✘	✘	3x3 DFN-12 MSOP-12

* In 2-Inductor Circuit, 500mA in 1-Indicator Configuration, † Current-Limited Ideal Diode V_{IN} to V_{OUT} , ‡ While Charging

LTC3225/-1: 150mA Supercapacitor Charger

Package: 2mm x 3mm DFN-10

Features:

- Low Noise Constant Frequency Charging of Two Series Supercapacitors
- Automatic Cell Balancing Prevents Capacitor Overvoltage During Charging
- Programmable Charging Current (Up to 150mA)
- Selectable 2.4V or 2.65V Regulation per Supercapacitor Cell (LTC3225)
- Selectable 2.0V and 2.25V Regulation per Supercapacitor Cell (LTC3225-1)
- Automatic Recharge
- $I_{VIN} = 20\mu$ A in Standby Mode
- $I_{VOUT} < 1\mu$ A When Input Supply is Removed
- No Inductors
- Tiny Application Circuit (2mm x 3mm DFN Package, All Components < 1mm High)

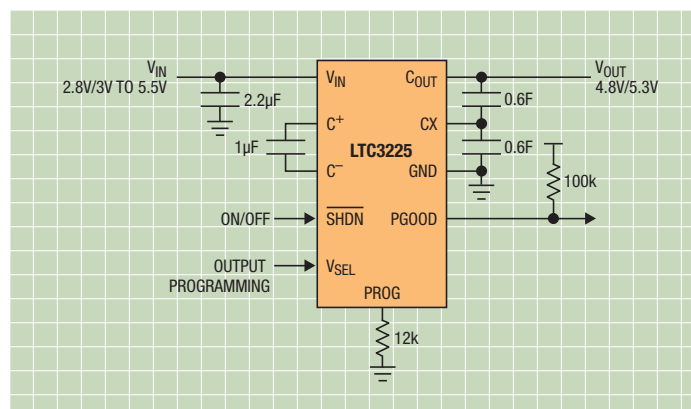

Charge Pump-Based Supercapacitor Charger

Special Functions/Battery Charger Support Devices

LTC4000: 60V Battery Charging Controller & Power Manager

Packages: 4mm x 5mm QFN-28 and SSOP-28

Features:

- Implements a Complete High Performance Battery Charger when Paired with a DC/DC Converter (Buck, Buck-Boost, Boost, SEPIC, Flyback)
- Wide Input and Output Voltage Range: 3V to 60V
- Input Ideal Diode for Low Loss Reverse Blocking and Load Sharing
- Output Ideal Diode for Low Loss PowerPath™ and Load Sharing with the Battery
- Instant-On Operation with Heavily Discharged Battery
- Programmable Input and Charge Current: $\pm 1\%$ Accuracy
- Accurate Programmable Float Voltage: $\pm 0.2\%$ at Room and $\pm 1\%$ Over Temperature
- Programmable C/X or Timer Based Charge Termination
- NTC Input for Temperature Qualified Charging
- 28-Lead 4mm x 5mm QFN or SSOP Packages

Target Applications:

- High Power Battery Charger Systems
- High Performance Portable Instruments
- Industrial Battery Equipped Devices
- Notebook/Subnotebook Computers
- General Purpose Charging

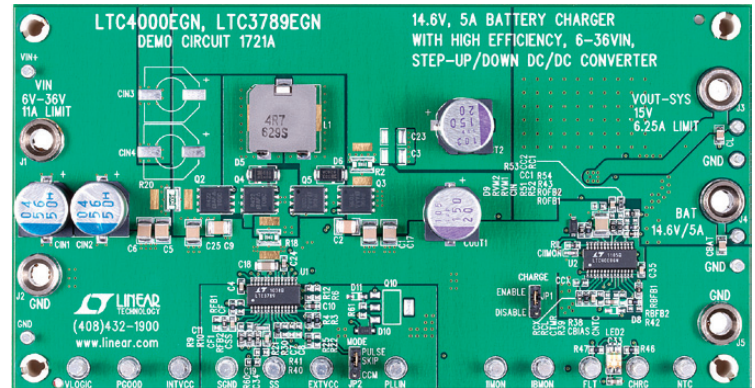

LTC4000 Demo Circuit

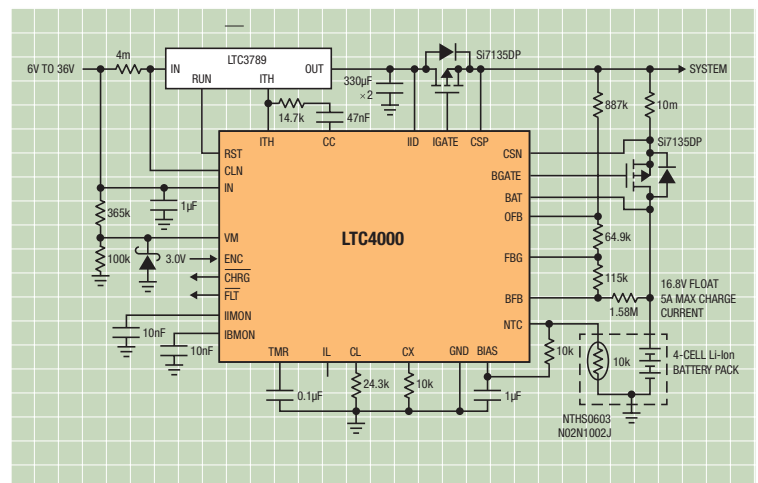

5A Buck-Boost Converter 4-Cell Li-Ion Battery Charger with 2.9h Timer Termination and 600mA Trickle Charge Current

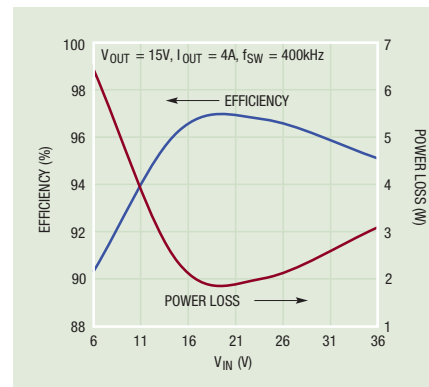

Efficiency and Power Loss for the LTC4000/LTC3789: 5A 4-Cell Li-Ion Battery Charger System

High Side and Low Side Current Sensing

Sensing and controlling current flow is a fundamental requirement in many battery charger and monitor applications.

High side current sense amplifiers extract small differential voltages from high common mode voltages. This is used to measure the voltage on a small sense resistor placed in series between a power supply and load, providing a direct measurement of current flowing into the load.

In some applications, low side current sensing can be used, where a sense resistor is placed between load and ground. The best solutions for low side sensing are micropower, rail-to-rail input amplifiers with low input bias current and low offset voltage.

For more information, see our complete current sense solutions guide at www.linear.com/currentsense

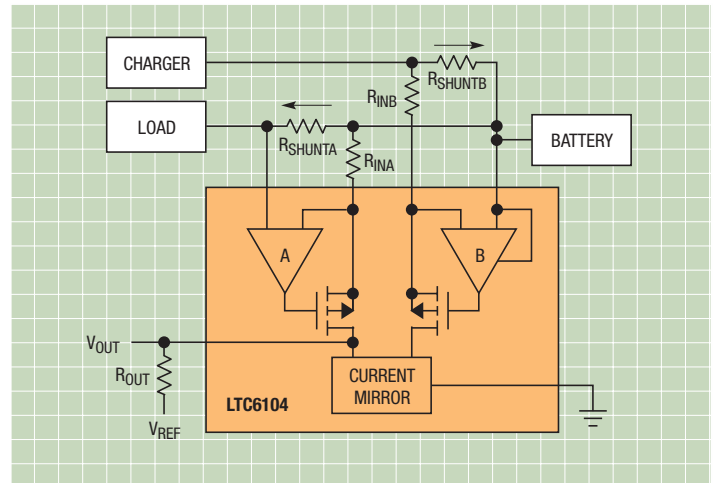

Dual Current Sensor for Charge and Discharge Monitoring

LTC6104: Dual Current Sensor for Charge and Discharge Monitoring

Part Number	Directional Sense	Input Voltage Range (V)	Response Time (μsec)	V_{OS} Max (μV)	V_{OS} Drift	I_{BIAS} Max	Gain	Package
High Side Current Sense Amplifiers								
LT1787	Bidirectional	2.5 to 40	10	75	0.5 $\mu\text{V}/^\circ\text{C}$	20 μA	Fixed $A_v=8$	SO-8, MSOP-8
LT1787HV	Bidirectional	2.5 to 65	10	75	0.5 $\mu\text{V}/^\circ\text{C}$	20 μA	Fixed $A_v=8$	SO-8, MSOP-8
LTC4151	Unidirectional	7 to 80	n/a	4000	n/a	n/a	n/a	DFN-10, MSOP-10
LT6100	Unidirectional	4.1 to 48	40	300	0.5 $\mu\text{V}/^\circ\text{C}$	10 μA	10,12.5,20,25,40,50V/V	DFN-8, MSOP-8
LTC6101	Unidirectional	4 to 70	1	300	1 $\mu\text{V}/^\circ\text{C}$	170nA	Adj w/ 2 Resistors	SOT-23, MSOP-8
LTC6101HV	Unidirectional	5 to 105	1	300	1 $\mu\text{V}/^\circ\text{C}$	170nA	Adj w/ 2 Resistors	SOT-23, MSOP-8
LTC6102	Unidirectional	4 to 70	1	10	50nV/ $^\circ\text{C}$	3nA	Adj w/ 2 Resistors	DFN-8, MSOP-8
LTC6102HV	Unidirectional	5 to 105	1	10	50nV/ $^\circ\text{C}$	3nA	Adj w/ 2 Resistors	DFN-8, MSOP-8
LTC6103	Unidirectional	4 to 70	1	450	1.5 $\mu\text{V}/^\circ\text{C}$	170nA	Adj w/ 2 Resistors	MSOP-8
LTC6104	Bidirectional	4 to 70	1	450	1.5 $\mu\text{V}/^\circ\text{C}$	170nA	Adj w/ 2 Resistors	MSOP-8
LT6105	Unidirectional	-0.3 to 44	3.5	300	1 $\mu\text{V}/^\circ\text{C}$	25 μA	Adj w/ 2 Resistors	DFN-6, MSOP-8
LT6106	Unidirectional	2.7 to 44	3.5	250	1 $\mu\text{V}/^\circ\text{C}$	40nA	Adj w/ 2 Resistors	SOT-23
LT6107	Unidirectional	2.7 to 44	3.5	250	1 $\mu\text{V}/^\circ\text{C}$	40nA	Adj w/ 2 Resistors	SOT-23

Part Number	Description	Rail-to-Rail	Direction Sense	Input Voltage Range (V)	V_{OS} Max (μV)	V_{OS} Drift	I_{BIAS} Max	Gain	Package
Low Side Current Sense Amplifiers									
LT1490A/91A	Dual/Quad Over-The-Top [®] μPower Rail-to-Rail Op Amps	In/Out	Bidirectional	2 to 44	500	4 $\mu\text{V}/^\circ\text{C}$	8nA	Adj w/ 2 Resistors	DFN-8, DIP-8, MSOP-8, SO-8, DIP-14, SO-14
LT1636	Over-The-Top Micropower Rail-to-Rail Single Supply Op Amp	In/Out	Bidirectional	2.6 to 44	225	5 $\mu\text{V}/^\circ\text{C}$	8nA	Adj w/ 2 Resistors	DFN-8, DIP-8, MSOP-8, SO-8
LT1638/39	1.2MHz, Over-The-Top Micropower Rail-to-Rail Op Amp	In/Out	Bidirectional	2.2 to 44	600	6 $\mu\text{V}/^\circ\text{C}$	50nA	Adj w/ 2 Resistors	DFN-8, DIP-8, MSOP-8, SO-8, DIP-14, SO-14
LTC2054/55	Single/Dual Low Power, Zero-Drift, 3V, 5V Op Amps	Out	Bidirectional	2.7 to 12	3	0.05 $\mu\text{V}/^\circ\text{C}$	3nA	Adj w/ 2 Resistors	ThinSOT, DFN-8, MSOP-8
LT6010/11/12	Single/Dual/Quad μPower Precision Rail-to-Rail Op Amps	Out	Bidirectional	2.7 to 40	35	0.8 $\mu\text{V}/^\circ\text{C}$	0.11nA	Adj w/ 2 Resistors	DFN-8, SO-8
LT6105	Precision, High Side or Low Side, Current Sense Amplifier	In	Unidirectional	-0.3 to 44	300	1 $\mu\text{V}/^\circ\text{C}$	25 μA	Adj w/ 2 Resistors	DFN-6, MSOP-8

High Voltage Battery Stack Monitoring

LTC6802: 44-Lead SSOP Supports Hybrid/Electric Vehicles and Battery Backup Systems

The LTC6802 is a highly integrated battery monitoring IC capable of measuring up to 12 individual cells. Using a unique level shifting technique, multiple LTC6802s can be stacked in series without optocouplers or isolators, allowing precision voltage monitoring of every cell in long strings of series-connected cells. Long cell strings enable high power, rechargeable battery applications, such as electric and hybrid electric vehicles, scooters, motorcycles, golf carts, wheelchairs, boats, forklifts, robotics, uninterruptible power supply systems and portable medical equipment.

With superior energy density, lithium-ion batteries are poised to be the power source of choice for these applications. However, designing a large, highly reliable and long lasting Li-Ion battery stack is a very complex problem. Li-Ion cells are sensitive to overcharging or over-discharging, requiring that each cell in a stack is carefully managed. The LTC6802 makes this possible with quick and accurate measurements of all cell voltages, even in the presence of stack voltages greater than 1000V+.

The maximum total measurement error is guaranteed to be less than 0.25% from -40°C to 85°C and all cell voltages in a battery stack can be measured within 13ms. Each cell is monitored for undervoltage and overvoltage conditions and an associated MOSFET switch is available to discharge overcharged cells. The LTC6802 communicates via a 1MHz serial interface. Also included are temperature sensor inputs, GPIO lines and a precision voltage reference.

The LTC6802 is designed for the environmental and reliability challenges of automotive and industrial applications. It is fully specified for operation from -40°C to 85°C and offers diagnostics and fault detection. The LTC6802 is available in a small 8mm x 13mm surface mount package. The combined robustness, exceptional precision and tiny package directly address the critical requirements of emerging and advanced battery technologies.

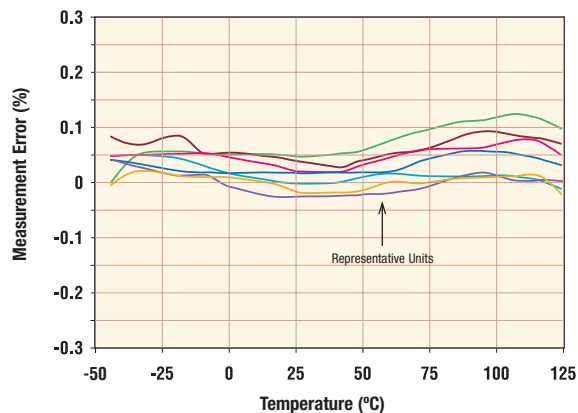

Cell Voltage Measurement Error Over Extended Temperature Range

Features:

- 0.25% Maximum Total Measurement Error from -40°C to 85°C
- Stackable Architecture Enables 1000V+ Systems
- Delta Sigma Converter with Built-In Noise Filter
- 1MHz Serial Interface with Packet Error Checking
- Onboard FETs for Cell Discharge
- Temperature Sensor Inputs
- Diagnostics and Fault Detection
- AEC-Q100 Qualified
- 44-Lead SSOP Package
- Fully Specified for -40°C to 85°C

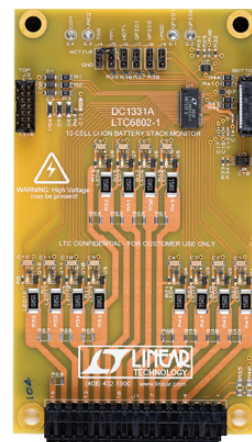

LTC6802:
Demo Board

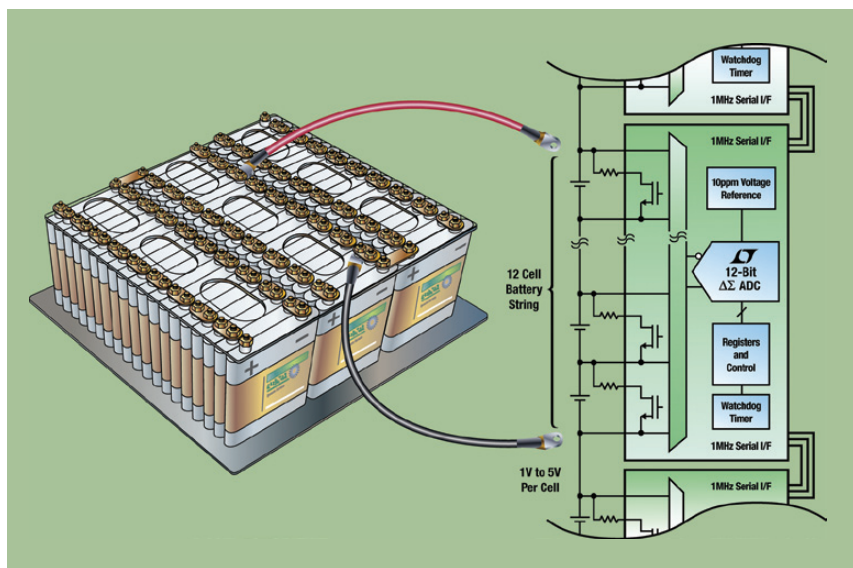

Rugged IC for Hybrid/Electric Vehicles and Battery Backup Systems

High Voltage Battery Stack Monitoring

LTC6801: Battery Stack Monitor IC Provides Independent Fault Detection

The LTC6801 is a high voltage battery stack fault monitor that operates without a microprocessor, and without the need for optocouplers or isolators. An LTC6801 can monitor up to 12 series-connected battery cells for overvoltage and undervoltage conditions. Multiple LTC6801 devices can be daisy chained, providing a method to monitor each individual cell in very long battery strings. When connected in a daisy-chain, a single differential clock output confirms that all cells in the stack are within the defined operating range. This clock interface provides high noise immunity and ensures that fault conditions are not hidden by frozen bits or short circuit conditions. The result is a reliable and simple design that can serve as a complete monitoring or redundant circuit. The LTC6801 is a low cost companion to the LTC6802 precision battery measurement and cell balancing IC, providing a backup circuit for hybrid electric battery packs, battery backup systems, and other high powered Li-Ion battery systems.

A wide range of overvoltage and undervoltage thresholds can be set via pin connections and the LTC6801 offers selectable threshold hysteresis and adjustable update rates. The LTC6801 is fully specified for operation from -40°C to 85°C and two temperature sensor inputs are monitored for overtemperature faults.

Features:

- Monitors Up to 12 Li-Ion Cells in Series (60V Max)
- Stackable Architecture Enables > 1000V Systems
- 1% Maximum Overvoltage Detection Level Error
- Adjustable Overvoltage and Undervoltage Detection
- Self-Test Features Guarantee Accuracy
- Robust Fault Detection Using Differential Signals
- Simple Pin-Strapped Configuration Allows Battery Monitoring without a Microcontroller
- 15.5ms to Monitor All Cells in a System
- Programmable Response Time
- Two Temperature Monitor Inputs
- Low Power Idle Mode
- 36-Lead SSOP Package

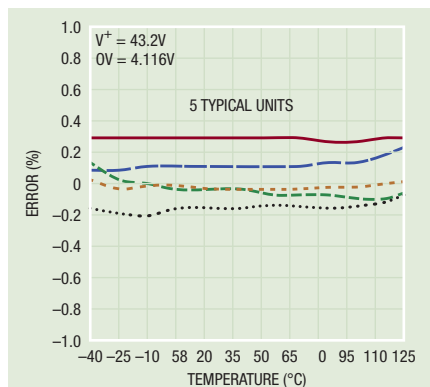

OV Detection Level Error

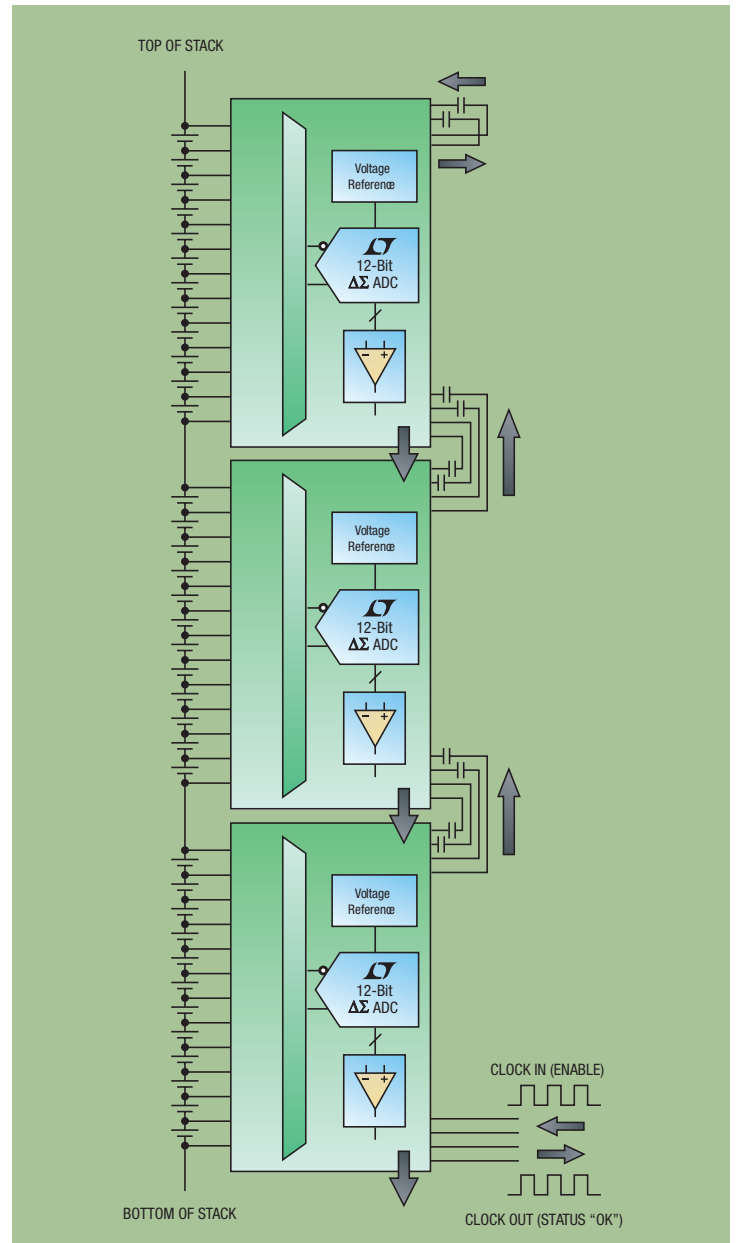

Differential Clock Signals are Transmitted Up and Down Stack via Daisy-Chain

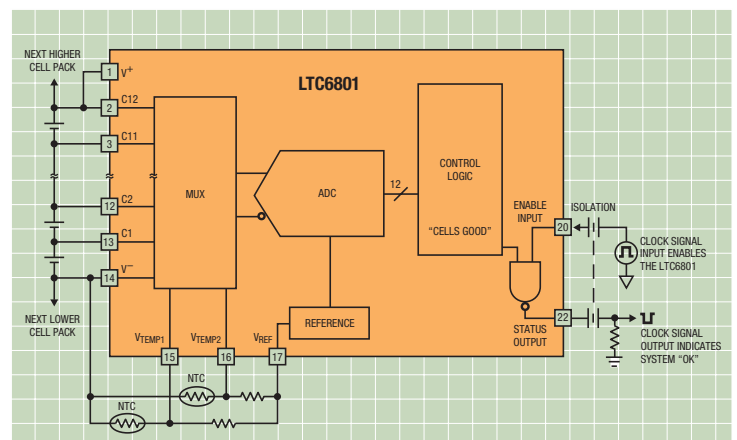

LTC6801 Block Diagram

Battery Monitoring Devices

By combining a voltage reference with a comparator, it is easy to create accurate battery monitors. Linear Technology offers a number of combination parts, with very low power and high accuracy voltage references. These parts are available in many pin configurations to support a wide range of designs with minimum package footprint and pin count.

The LT6700 is an ideal choice for a micropower “gas gauge” because of its accuracy (<2% total threshold error over temperature). As shown, it is simple to implement a 2-threshold “alkaline-cell” battery monitor. In this example, the bottom comparator output goes low when the pack voltage falls below 2V (1V per cell), which corresponds to about 30% capacity remaining. The top comparator output goes low when the pack voltage falls below 1.6V (0.8V per cell), indicating that the battery pack has reached its rated end-of-life voltage. The number of threshold points can be increased by extending the resistor-divider chain and using additional comparators.

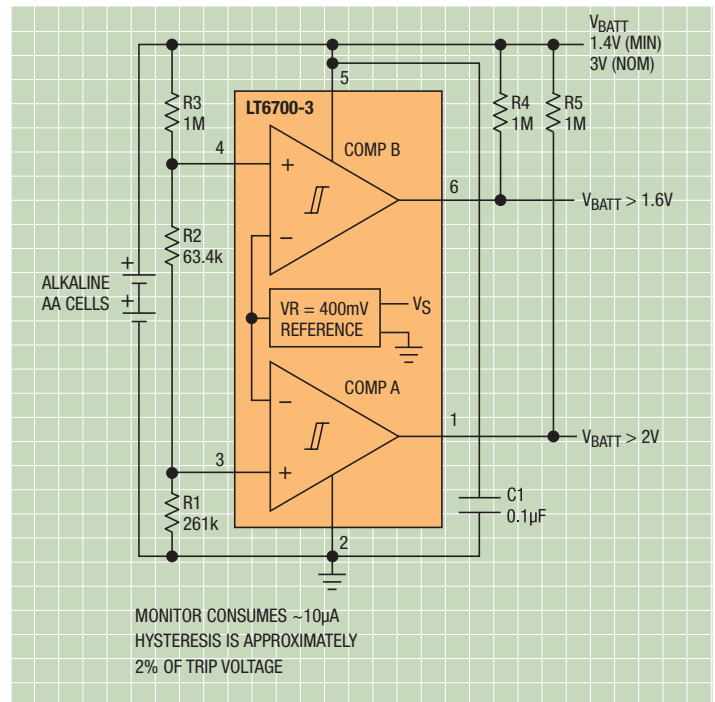

Micropower Battery Monitor

LT6700-3: Micropower, Low Voltage, Dual Comparator with 400mV Reference

Part Number	Description	Supply Voltage (V)	Prop Delay (µs) Typ	Hysteresis (mV)	Supply Current (µA)	Package (mm x mm)
Comparator and Reference Combinations						
LT6700	Dual Comparators with 400mV Reference	1.4 to 18	18	6.5	10	SOT-23, 2x3 DFN-6
LT6700HV	36V Input/Output Dual Comparators and Reference	1.4 to 18	18	6.5	10	SOT-23
LT6700MP	Dual Comparators and Reference for -55°C to 150°C	1.4 to 18	18	6.5	10	2x3 DFN-6
LT6703	Single Comparator and Internal Reference	1.4 to 18	18	6.5	10	SOT-23, 2x2 DFN-3
LT6703HV	36V Input/Output Comparator and Reference	1.4 to 18	18	6.5	10	SOT-23
LTC1440	Ultralow Power Comparator with Reference	2 to 11	8	Adj	4	MSOP-8, SO-8, DIP-8, 3x3 DFN-8
LTC1441	Dual Ultralow Power Comparators with Reference	2 to 11	8	None	5.7	DIP-8, SO-8
LTC1442	Dual Ultralow Power Comparators with Reference	2 to 11	8	Adj	5.7	DIP-8, SO-8
LTC1443	Quad Ultralow Power Comparators with Reference	2 to 11	4	None	8.5	DIP-16, SO-16, 4x5 DFN-16
LTC1444	Quad Ultralow Power Comparators with Reference	2 to 11	4	Adj	8.5	DIP-16, SO-16, 4x5 DFN-16
LTC1445	Quad Ultralow Power Comparators with Reference	2 to 11	4	Adj	8.5	DIP-16, SO-16, 4x5 DFN-16
LTC1540	Nanopower Comparator with Reference	2 to 11	50	Adj	0.7	MSOP-8, SO-8, 3x3 DFN-8
LTC1541	Combined Amplifier, Comparator and Reference	2.5 to 12.6	8	2.25	7.5	MSOP-8, SO-8, 3x3 DFN-8
LTC1542	Micropower Amplifier and Comparator	2.5 to 12.6	8	2.25	5	MSOP-8, SO-8, 3x3 DFN-8
LTC1842	Dual Ultralow Power Comparators with Reference	2.5 to 11	4	Adj	5.7	SO-8
LTC1843	Dual Ultralow Power Comparators with Reference	2.5 to 11	4	Adj	5.7	SO-8
LTC1998	High Accuracy Comparator with 1.2V Reference	1.5 to 5.5	150	Adj	3.5	SOT-23

MASTER INDEX – Power Managers and Linear Battery Chargers

Battery Number of Battery Cells (Series)	Battery Charge Current (Max), A	Charge Termination & Integration			Status Signals			Temperature Control			Package	Part Number	Page Number
		Standalone	Charge Termination	Integrated Pass Transistor	I _{CHARGE} Monitor #	End-of-Charge Signal	AC Present Signal	Thermal Regulation	Thermistor Interface				
Li-Ion/Polymer 4.2V/Cell & 4.1V/Cell Linear Battery Chargers with PowerPath Control (Power Managers)													
1	3.5	✓	✓ [§]	✓	✓	✓	-	✓ [#]	✓	✓	QFN-28	LTC4155	7, 10
1	3.5	✓	✓ [§]	✓	✓	✓	-	✓ [#]	✓	✓	QFN-28	LTC4156 ††	10
1	1.5	✓	✓ [§]	✓	✓	✓	-	✓	✓	✓	QFN-20	LTC4099	7, 10
1	1.5	✓	✓ [§]	✓	✓	✓	-	✓	✓	✓	QFN-20	LTC4160	7, 10
1	1.5	✓	✓ [§]	✓	✓	✓	-	✓	✓	✓	QFN-20	LTC4098	7, 10
1	1.5	✓	✓ [§]	✓	✓	✓	-	✓	✓	✓	QFN-20	LTC4098-3.6 ††	7, 10
1	1.5	✓	✓ [§]	✓	✓	✓	-	✓	✓	✓	DFN-14	LTC4088	10
1	1.2	✓	✓ [§]	✓	✓	✓	✓	✓	✓	✓	DFN-22	LTC4090	10
1	1.2	✓	✓ [§]	✓	✓	✓	✓	✓	✓	✓	DFN-22	LTC4089	7, 10
1	1.5	✓	✓ [‡]	✓	✓ ^{**}	✓	✓	✓	✓	✓	QFN-24	LTC4066	7, 10
1	1.25	✓	✓ [‡]	✓	✓	✓	✓	✓	✓	✓	QFN-16	LTC4055	7, 10
1	1.25	✓	✓ [‡]	✓	✓	✓	-	✓	✓	✓	DFN-12	LTC4067	10
1	1.5	✓	✓ [‡]	✓	✓	✓	✓	✓	✓	✓	DFN-14	LTC4085	7, 10
Li-Ion/Polymer 4.2V/Cell & 4.1V/Cell Linear Battery Chargers													
1	1	✓	✓ [§]	✓	✓	✓	✓	✓	✓	✓	DFN-10	LTC4061	6
1	1	✓	✓ [§]	✓	✓	✓	-	✓	✓	✓	DFN-10	LTC4062	6
1	1	✓	✓ [§]	✓	✓	✓	-	✓	✓	✓	DFN-10	LTC4063	6
1	2	✓	✓ [‡]	✓	✓	✓	✓	-	✓	✓	MSOP-10	LTC4050	6, 7
1	1.25	✓	✓ [‡]	✓	✓	✓	✓	✓	✓	✓	DFN-10	LTC4053	6
1	0.95	✓	✓ [‡]	✓	✓	✓	✓	✓	✓	✓	MSOP-10	LTC4078/X	6
1	0.95	✓	✓ [‡]	✓	✓	✓	✓	✓	✓	✓	DFN-10	LTC4075/X	6
1	1.2	✓	✓ [‡]	✓	✓	✓	✓	✓	✓	✓	DFN-10	LTC4096/X	6

* Current C/10, † Current C/x, ‡ Timer, § µC, ¶ Timer + Current Indication, # PROG Pin Tracks Charge Current, ** Gas Gauge Capability, †† For 1-Cell LiFePO₄, ††† Thermal Shutdown

Most ← → Least
Integration/Features

MASTER INDEX – Power Managers and Linear Battery Chargers (Continued)

Battery Number of Battery Cells (Series)	Battery Charge Current (Max), A	Charge Termination & Integration			Status Signals			Temperature Control		Package	Part Number		Page Number
		Stand-alone	Charge Termination	Integrated Pass Transistor	CHARGE Monitor #	End-of-Charge Signal	AC Present Signal	Thermal Regulation	Thermistor Interface		Most ←	→ Least	
Li-Ion/Polymer 4.2V/Cell & 4.1V/Cell Linear Battery Chargers													
1	0.95	✓	✓†	✓	✓	✓	✓	✓	✓	DFN-10	LTC4077	6	
1	0.95	✓	✓†	✓	✓	✓	✓	✓	✓	DFN-10	LTC4076	6	
1	0.95	✓	✓¶	✓	✓	✓	✓	✓	✓	DFN-8	LTC4095	6	
1	0.95	✓	✓†	✓	✓	✓	✓	✓	✓	DFN-8	LTC4068X	6	
1	0.95	✓	✓•	✓	✓	✓	✓	✓	✓	DFN-8	LTC4058X	6	
1, 2	2	✓	✓†	✓	✓	✓	✓	✓	✓	MSOP-10	LTC1732	6, 7	
1, 2	2	✓	✓†	✓	✓	✓	✓	✓	✓	MSOP-8	LTC1731	6, 7	
1	1.5	✓	✓†	✓	✓	✓	✓	✓	✓	MSOP-10E	LTC1733	6, 7	
1	0.8	✓	✓•	✓	✓	✓	✓	✓	✓	ThinSOT	LTC4054X	6	
1	0.75	✓	✓¶	✓	✓	✓	✓	✓	✓	DFN-6	LTC4070	6	
1	0.75	✓	✓†	✓	✓	✓	✓	✓	✓	DFN-6	LTC4065/A	6	
1	0.7	✓	✓†	✓	✓	✓	✓	✓	✓	ThinSOT	LTC4056	6	
1	0.9	✓	✓\$	✓	✓	✓	✓	✓	✓	DFN-6	LTC4059/A	6, 8	
1	0.8	✓	✓\$	✓	✓	✓	✓	✓	✓	ThinSOT	LTC4057	6	
1	1	✓	✓†	✓	✓	✓	✓	✓	✓	MSOP-10E	LTC4064	6, 7	
1	0.7	✓	✓\$	✓	✓	✓	✓	✓	✓	ThinSOT	LTC1734	6, 7	
Li-Ion/Polymer Coin Cell Battery Chargers													
1	0.15	✓	✓•	✓	✓	✓	✓	✓	✓	ThinSOT	LTC4054L	6, 8	
1	0.9	✓	✓\$	✓	✓	✓	✓	✓	✓	DFN-6	LTC4059/A	6	
1	0.25	✓	✓†	✓	✓	✓	✓	✓	✓	DFN-6	LTC4065L/LX	6, 8	
1	50mA††	✓	✓	✓	✓	✓	✓	✓	✓	2x3 DFN-8, MSOP-8E	LTC4070	7, 8	
1	50mA	✓	✓	✓	✓	✓	✓	✓	✓	2x3 DFN-8, MSOP-8E	LTC4071	7, 8	
1	0.18	✓	✓\$	✓	✓	✓	✓	✓	✓	ThinSOT	LTC1734L	6, 8	

* Current C/10. † Current C/x. ‡ Timer. § µC. ¶ Timer + Current Indication. # PROG Pin Tracks Charge Current. ** Gas Gauge Capability. †† 500mA With External PFET

MASTER INDEX – Switch Mode Battery Chargers

Battery	Battery Charge		Charge Termination & Integration			Status Signals			Temperature Control		Package	Part Number	Page Number
	Number of Battery Cells (Series)	Current (Max), A	Stand-alone	Charge Termination	Integrated Power	Charge Monitor ^{††}	End-of-Charge Signal	AC Present Signal	Thermal Regulation	Thermistor Interface			
NiMH/NiCd Battery Chargers													
1-16	4		✓	✓ [#]	-	-	✓	✓	-	✓	TSSOP-20E	LTC4011 Switch Mode	9
1-16	4		✓	✓ [#]	-	-	✓	✓	-	✓	TSSOP-16E	LTC4010 Switch Mode	9
1-4	2		✓	✓ [§]	-	-	✓	✓	-	✓	DFN-16 TSSOP-16	LTC4060 Linear	9
Li-Ion/Polymer Switch Mode Battery Chargers													
1	4		✓	✓ ^{**}	✓	-	✓	✓	✓	✓	QFN-36	LT3651-4.x	7, 14
2	4		✓	✓ ^{**}	✓	-	✓	✓	✓	✓	QFN-36	LT3651-8.x	7, 14
1	2		✓	✓ [†]	✓	-	-	✓	-	✓	SSOP-24	LTC4001/-1	7, 14
1-2	2		✓	✓ ^{**}	✓	-	-	✓	✓	✓	DFN-12	LT3650	7, 14
3-4	4		✓	✓ [†]	-	✓	✓	✓	-	✓	SSOP-24	LTC4007	7, 14
2-4	4		✓	✓ [†]	-	✓	✓	✓	-	✓	SSOP-16	LTC4006	14
1-2	2		✓	✓ [†]	-	-	-	-	-	-	SSOP-24	LTC1980	7
1-2, adj	1.5		-	✓ ^{†††}	✓	-	-	-	-	-	SSOP-16 SSOP-28	LT1571	14
1-2	4		✓	✓ [†]	-	-	✓	✓	-	✓	DFN-10 SO-8	LTC4002	14

* Current C/10, † Current C/x, ‡ Timer, § T, t, -dV, # T, t, -dV, ** Timer + Current, †† for Li-Ion Termination, use LTC1729, ††† PROG Pin Tracks Charge Current

Most ← Integration/Features → Least

MASTER INDEX – Switch Mode Battery Chargers (Continued)

Battery	Charge Termination & Integration		Status Signals	Temperature Control		Package	Part Number	Page Number				
V_{BAT} Range, V	Battery Charge Current (Max), A	Standalone	Charge Termination Method(s)	Integrated Pass Transistor	Monitor ^{††}	End-of-Charge Signal	AC Present Signal	Thermal Regulation	Thermistor Interface	Integration/Features		
Smart Battery Chargers												
3.5-18	3	✓	SMBus ^{††}	-	-	-	✓	-	-	Least	LTC4110	7, 15, 16
3.5-28	4	✓	SMBus [†]	-	-	-	-	-	✓	Most	LTC1760	7, 16
3-21	8	✓	SMBus [†]	-	-	-	✓	-	✓		LTC1759	9, 16
3.5-26	4	✓	SMBus [†]	-	-	-	✓	-	✓		LTC4100	7, 16
3.0-5.5	4	✓	SMBus [†]	-	-	-	✓	-	✓		LTC4101	16
Lead Acid, Li-Ion/Polymer, NiMH/NiCd Switch Mode Battery Chargers												
3.5-28	8	-	SP [†]	-	-	-	-	-	-		LTC1960	7, 9, 14, 16
2.5-23	8	-	✓ ^{††}	-	-	✓	-	-	-		LT1505	9, 14
3.3-18	2	✓	✓ ^{**}	✓	-	✓	-	✓	✓		LT3652HV	14
3.3-14.4	2	✓	✓ ^{**}	✓	-	✓	-	✓	✓		LT3652	14
2-28	4	-	✓ [†]	-	✓	-	✓	✓	-		LTC4012/-1/-2/-3	7, 9, 14
2-28	4	-	✓ [†]	-	✓	-	✓	✓	-		LTC4009/-1/-2	7, 9, 14
3-28	4	-	✓ [†]	-	-	✓	✓	-	✓		LTC4008	7, 9, 14
2.5-26	3	-	✓ ^{††}	✓	-	-	-	-	-		LT1511	9, 14
1.5-20	0.75	-	✓ ^{††}	✓	-	-	-	-	-		LT1512	9, 15
1.5-20	2	-	✓ ^{††}	✓	-	-	-	-	-		LT1513	9, 15
2.5-26	2	-	✓ ^{††}	✓	-	-	-	-	-		LT1769	9, 14
2.5-26	1.5	-	✓ ^{††}	✓	-	-	-	-	-		LT1571	14
2.5-26	1	-	✓ ^{††}	✓	-	-	-	-	-		LT1510	9, 14

* Current C/10, † Current Cx, †† Timer, † μC, †† L, -dV, dI/dt, ** Timer + Current, †† for Li-Ion Termination, use LTC1729, †† PROG Pin Tracks Charge Current

MASTER INDEX – Multifunction PMICs

Onboard Regulators			Battery Charger/Power Manager				Other Features		Part Number	Integration/Features	Page #	
Number of Regulators	Buck(s) (I _{OUT})	Buck-Boost (BB)/ Boost	LD(s) (I _{OUT})	Li-Ion/Polymer Charger	Maximum Charge Current (A)	PowerPath Topology	Ideal Diode	Input Voltage (V)				Interface
Li-Ion/Polymer Multifunction Power Management Integrated Circuits (PMICs)												
5	400mA x 2	1A BB, 0.8A Boost	3.3V, 20mA	Sync Buck + Linear	1.5	Switch Mode	Int + Ext (opt.)	5, USB, Li Ion	-	4x6 QFN-38	LTC3586/-1	7, 11
5	600mA, 400mA x 2	10-LED Boost	2 x 150mA	Linear	1.5	Linear	Int + Ext (opt.)	5, USB, Li Ion, Hi-V Bat-Track, OVP	-	4x7 QFN-44	LTC3577/-1/-3/-4	7, 12
4	600mA, 400mA x 2	-	2 x 150mA	Linear	1.5	Linear	Int + Ext (opt.)	5, USB, Li Ion, Hi-V Bat-Track, OVP	-	4x7 QFN-44	LTC3677/-3	12
4	400mA x 2, 1A	-	3.3V, 20mA	Sync Buck + Linear	1.5	Switch Mode	Int + Ext (opt.)	5, USB, Li-Ion, Hi-V 38V with 60V transients; OVP: 68V	I ² C	4x6 QFN-38	LTC3576/-1	7, 11
4	400mA x 2	1A BB	3.3V, 25mA	Sync Buck + Linear	1.5	Switch Mode	Int + Ext (opt.)	5, USB, Li Ion	I ² C	4x5 QFN-28	LTC3556	11
4	600mA, 400mA x 2	-	3.3V, 25mA	Linear	1.5	Linear	Int + Ext (opt.)	5, USB, Li Ion, Hi-V 38V max	-	4x4 QFN-28	LTC3557/-1	7, 12
4	1A, 400mA x 2	-	3.3V, 25mA	Sync Buck + Linear	1.5	Switch Mode	Int + Ext (opt.)	5, USB, Li Ion	I ² C	4x5 QFN-24	LTC3555/-1/-3	7, 11
3	400mA, 600mA	-	Flexible Gain Block for LDO Controller	Linear	0.5	Linear	-	5, USB, Li Ion	-	4x4 QFN-24	LTC3455/-1	7, 12
2	-	1A BB	3.3V, 25mA	Sync Buck + Linear	1.5	Switch Mode	Int + Ext (opt.)	4.25 to 5.5	-	4x4 QFN-24	LTC3566	11
2	-	1A BB	3.3V, 25mA	Sync Buck + Linear	1.5	Switch Mode	Int + Ext (opt.)	4.25 to 5.5	I ² C	4x4 QFN-24	LTC3567	11
2	200mA x 2	-	-	Linear	0.5	Linear	-	4.35V to 5.5V	-	3x3 QFN-20	LTC3554	12
2	200mA	-	150mA	Linear	0.5	Linear	-	4.35V to 5.5V	-	3x3 QFN-20	LTC3553	12
2	400mA	0.4A BB	-	Linear	0.95	-	-	5, USB	-	3x3 QFN-20	LTC3558	13
2	400mA x 2	-	-	Linear	0.95	-	-	5, USB	-	3x3 QFN-16	LTC3559/-1	7, 13
2	400mA, 800mA	-	-	Linear	0.95	-	-	4.25 to 8	-	3x5 DFN-16	LTC3552/-1	13
1	600mA	-	-	Linear	0.95	-	-	4.3 to 8	-	3x5 DFN-16	LTC3550/-1	13
1	300mA	-	-	Linear	0.5	-	-	2.7 to 4.5	-	3x3 DFN-10, MSOP-10E	LTC4080	13
1	300mA	-	-	Linear	0.5	-	-	2.7 to 4.5	-	3x3 DFN-10	LTC4081	13

NORTH AMERICA

NORTHERN CALIFORNIA/ NEVADA

Bay Area

720 Sycamore Dr.
Milpitas, CA 95035
Tel: (408) 428-2050
Fax: (408) 432-6331

Sacramento/Nevada

2260 Douglas Blvd., Ste. 280
Roseville, CA 95661
Tel: (916) 787-5210
Fax: (916) 787-0110

PACIFIC NORTHWEST

Denver

7007 Winchester Cir., Ste. 130
Boulder, CO 80301
Tel: (303) 926-0002
Fax: (303) 530-1477

Portland

5005 SW Meadows Rd., Ste. 410
Lake Oswego, OR 97035
Tel: (503) 520-9930
Fax: (503) 520-9929

Salt Lake City

Tel: (801) 731-8008

Seattle

2018 156th Ave. NE, Ste. 100
Bellevue, WA 98007
Tel: (425) 748-5010
Fax: (425) 748-5009

SOUTHWEST AREA

Los Angeles

21243 Ventura Blvd., Ste. 238
Woodland Hills, CA 91364
Tel: (818) 703-0835
Fax: (818) 703-0517

Orange County

15375 Barranca Pkwy., Ste. A-213
Irvine, CA 92618
Tel: (949) 453-4650
Fax: (949) 453-4765

Phoenix

2085 E. Technology Cir., Ste. 101
Tempe, AZ 85284
Tel: (480) 777-1600
Fax: (480) 838-1104

San Diego

5090 Shoreham Place, Ste. 110
San Diego, CA 92122
Tel: (858) 638-7131
Fax: (858) 638-7231

CENTRAL AREA

Chicago

2040 E. Algonquin Rd., Ste. 512
Schaumburg, IL 60173
Tel: (847) 925-0860
Fax: (847) 925-0878

Cleveland

7550 Lucerne Dr., Ste. 106
Middleburg Heights, OH 44130
Tel: (440) 239-0817
Fax: (440) 239-1466

Columbus

Tel: (614) 488-4466

Detroit

39111 West Six Mile Road
Livonia, MI 48152
Tel: (734) 779-1657
Fax: (734) 779-1658

Indiana

Tel: (317) 581-9055

Iowa

Tel: (847) 925-0860

Kansas

Tel: (913) 829-8844

Minneapolis

7805 Telegraph Rd., Ste. 225
Bloomington, MN 55438
Tel: (952) 903-0605

Wisconsin

Tel: (262) 697-5001

NORTHEAST AREA

Boston

15 Research Place
North Chelmsford, MA 01863
Tel: (978) 656-4750
Fax: (978) 656-4760

Connecticut

Tel: (860) 228-4104

Philadelphia

3220 Tillman Dr., Ste. 120
Bensalem, PA 19020
Tel: (215) 638-9667
Fax: (215) 638-9764

SOUTHEAST AREA

Atlanta

Tel: (770) 888-8137

Austin

8500 N. Mopac, Ste. 603
Austin, TX 78759
Tel: (512) 795-8000
Fax: (512) 795-0491

Dallas

2301 W. Plano Pkwy., Ste. 109
Plano, TX 75075
Tel: (972) 733-3071
Fax: (972) 380-5138

Fort Lauderdale

Tel: (954) 473-1212

Houston

1080 W. Sam Houston Pkwy.
Ste. 225
Houston, TX 77043
Tel: (713) 463-5001
Fax: (713) 463-5009

Huntsville

Tel: (256) 881-9850

Orlando

Tel: (407) 688-7616

Raleigh

15100 Weston Pkwy.
Ste. 202
Cary, NC 27513
Tel: (919) 677-0066
Fax: (919) 678-0041

Tampa

Tel: (813) 634-9434

CANADA

Calgary, AB

Tel: (403) 455-3577

Montreal, QC

Tel: (450) 689-2660

Ottawa, ON

Tel: (613) 691-0486

Toronto, ON

Tel: (440) 239-0817

Vancouver, BC

Tel: (604) 729-1204

ASIA

AUSTRALIA/NEW ZEALAND

Linear Technology Corporation
133 Alexander Street
Crowns Nest NSW 2065
Australia
Tel: +61 (0)2 9432 7803
Fax: +61 (0)2 9439 2738

CHINA

Linear Technology Corp. Ltd.
Units 1503-04, Metroplaza Tower 2
223 Hing Fong Road
Kwai Fong, N.T., Hong Kong
Tel: +852 2428-0303
Fax: +852 2348-0885

Linear Technology Corp. Ltd.

Room 2701, City Gateway
No. 398 Cao Xi North Road
Shanghai, 200030, PRC
Tel: +86 (21) 6375-9478
Fax: +86 (21) 5465-5918

Linear Technology Corp. Ltd.

Room 816, 8/F
China Electronics Plaza B
No. 3 Dan Ling Rd., Hai Dian District
Beijing, 100080, PRC
Tel: +86 (10) 6801-1080
Fax: +86 (10) 6805-4030

Linear Technology Corp. Ltd.

Room 2604, 26/F
Excellence Times Square Building
4068 Yitian Road, Futian District
Shenzhen, 518048, PRC
Tel: +86 755-8236-6088
Fax: +86 755-8236-6008

JAPAN

Linear Technology KK

8F Shuwa Kioicho Park Bldg.
3-6 Kioicho Chiyoda-ku
Tokyo, 102-0094, Japan
Tel: +81 (3) 5226-7291
Fax: +81 (3) 5226-0268

Linear Technology KK

6F Kearny Place Honmachi Bldg.
1-6-13 Awaza, Nishi-ku
Osaka-shi, 550-0011, Japan
Tel: +81 (6) 6533-5880
Fax: +81 (6) 6543-2588

Linear Technology KK

7F, Sakuradori Ohtsu KT Bldg.
3-20-22 Marunouchi, Naka-ku
Nagoya-shi, 460-0002, Japan
Tel: +81 (52) 955-0056
Fax: +81 (52) 955-0058

KOREA

Linear Technology Korea Co., Ltd.

Yundang Building, #1002
Samsung-Dong 144-23
Kangnam-Ku, Seoul
135-090 Korea
Tel: +82 (2) 792-1617
Fax: +82 (2) 792-1619

SINGAPORE

Linear Technology Pte. Ltd.

507 Yishun Industrial Park A
Singapore 768734
Tel: +65 6753-2692
Fax: +65 6752-0108

TAIWAN

Linear Technology Corporation

8F-1, 77, Nanking E. Rd., Sec. 3
Taipei, Taiwan
Tel: +886 (2) 2505-2622
Fax: +886 (2) 2516-0702

EUROPE

FINLAND

Linear Technology AB
Teknobulevardi 3-5
P.O. Box 35
FIN-01531 Vantaa
Finland
Tel: +358 (0)46 712 2171
Fax: +358 (0)46 712 2175

FRANCE

Linear Technology S.A.R.L.
Parc Tertiaire Silic
2 Rue de la Couture, BP10217
94518 Rungis Cedex
France
Tel: +33 (1) 56 70 19 90
Fax: +33 (1) 56 70 19 94

GERMANY

Linear Technology GmbH
Osterfeldstrasse 84, Haus C
D-85737 Ismaning
Germany
Tel: +49 (89) 962455-0
Fax: +49 (89) 963147

Linear Technology GmbH

Haselburger Damm 4
D-59387 Ascheberg
Germany
Tel: +49 (2593) 9516-0
Fax: +49 (2593) 951679

Linear Technology GmbH

Jesinger Strasse 65
D-73230 Kirchheim/Teck
Germany
Tel: +49 (0)7021 80770
Fax: +49 (0)7021 807720

ITALY

Linear Technology Italy Srl

Orione 3, C.D. Colleoni
Via Colleoni, 17
I-20041 Agrate Brianza (MI)
Italy
Tel: +39 039 596 5080
Fax: +39 039 596 5090

SWEDEN

Linear Technology AB

Electrum 204
Isafjordsgatan 22
SE-164 40 Kista
Sweden
Tel: +46 (8) 623 16 00
Fax: +46 (8) 623 16 50

UNITED KINGDOM

Linear Technology (UK) Ltd.

3 The Listons, Liston Road
Marlow, Buckinghamshire SL7 1FD
United Kingdom
Tel: +44 (1628) 477066
Fax: +44 (1628) 478153

 Linear Technology, LT, LTC, Burst Mode, Over-The-Top and the Linear logo are registered trademarks and Bat-Track, Hot Swap, PowerPath, and ThinSOT are trademarks of Linear Technology Corporation. All other trademarks are the property of their respective owners.

© 2011 Linear Technology Corporation



Linear Technology Corporation

1630 McCarthy Blvd. Milpitas, CA 95035-7417 • Tel: 408-432-1900 • www.linear.com

WF0611OLU